



数字图象处理

中国科学技术大学
电子工程与信息科学系

主讲教师：李厚强 (lihq@ustc.edu.cn)

周文罡 (zhwg@ustc.edu.cn)

助 教：姚金辰 (yaojinchen@mail.ustc.edu.cn)

杜 锐 (ruidu@mail.ustc.edu.cn)

范昊源 (fanhaoyuan@mail.ustc.edu.cn)

翁博洪 (bhweng@mail.ustc.edu.cn)

课件下载：<https://ustc-dip.github.io/>



第4章 频率域滤波

- 4.1 离散傅立叶变换(DFT)
- 4.2 频率域滤波基础
- 4.3 频率域滤波器平滑图像
- 4.4 频率域滤波器锐化图像
- 4.5 选择性滤波



第4章 频率域滤波：图像变换

动机：为了有效和快速地对图象进行处理，常常需要将原定义在图象空间的图象，以某种形式转换到另外一些空间（频率域空间）并加工，最后再转换回图象空间以得到所需的效果。

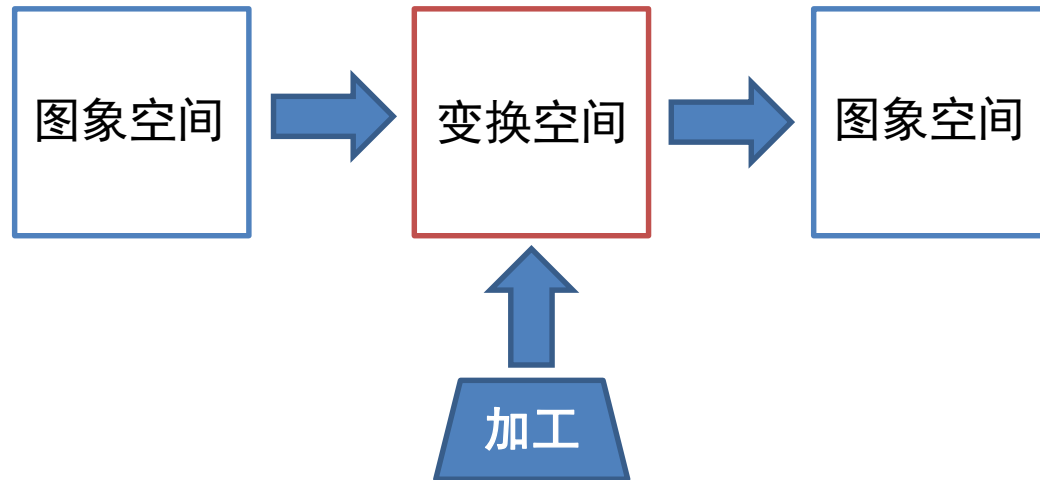



第4章 频率域滤波

- 4.1 离散傅立叶变换(DFT)
- 4.2 频率域滤波基础
- 4.3 频率域滤波器平滑图像
- 4.4 频率域滤波器锐化图像
- 4.5 选择性滤波

4.1 傅立叶变换基础

□ 傅里叶级数 (FS)

- 任何周期函数都可以表示为不同频率的正弦或余弦之和的形式，每个正弦项和余弦项都乘以不同的系数

$$f(t) = \sum_{n=-\infty}^{\infty} c_n e^{j\frac{2\pi n}{T}t}$$

$$c_n = \frac{1}{T} \int_{-\frac{T}{2}}^{\frac{T}{2}} f(t) e^{j\frac{2\pi n}{T}t} dt, \quad n = 0, \pm 1, \pm 2, \dots$$

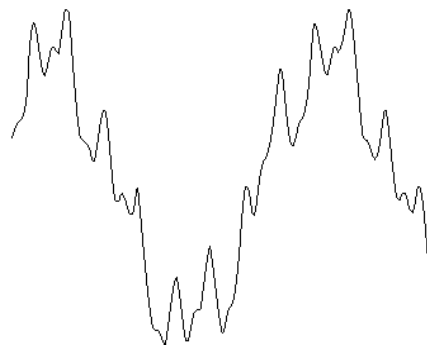
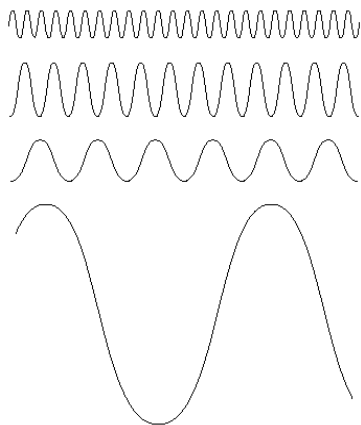

FIGURE 4.1 The function at the bottom is the sum of the four functions above it. Fourier's idea in 1807 that periodic functions could be represented as a weighted sum of sines and cosines was met with skepticism.



4.1 傅立叶变换基础

□ 傅里叶变换 (FT)

- 任何**非周期函数**（其曲线下的面积是有限的，即绝对可积）可以表示为正弦和/或余弦乘以加权函数的积分来表示
- 连续函数 $f(t)$ 的傅里叶变换 $F(\mu)$ 定义如下：

$$\begin{aligned} F(\mu) &= \int_{-\infty}^{\infty} f(t) e^{-j2\pi\mu t} dt \\ &= \int_{-\infty}^{\infty} f(t) [\cos(2\pi\mu t) - j\sin(2\pi\mu t)] dt \end{aligned}$$

- 给定 $F(u)$ ，通过傅里叶反变换可得到 $f(t)$ ：

$$f(t) = \int_{-\infty}^{\infty} F(u) e^{j2\pi\mu t} d\mu$$

4.1 傅立叶变换基础

□ 连续变量函数的傅里叶变换：窗函数

$$F(\mu) = AW \frac{\sin(\pi\mu W)}{\pi\mu W}$$

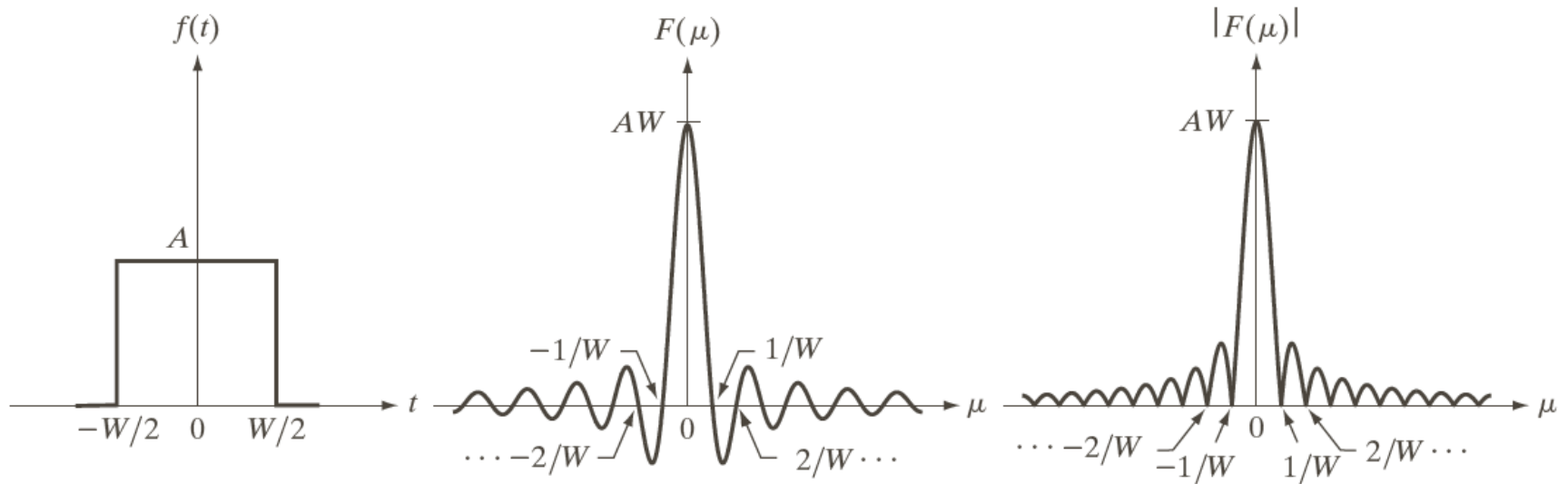

a b c

FIGURE 4.4 (a) A simple function; (b) its Fourier transform; and (c) the spectrum. All functions extend to infinity in both directions.



4.1 傅立叶变换基础

□ 卷积定理

- 对于具有连续变量 t 的两个连续函数 $f(t)$ 和 $h(t)$ 的卷积

$$f(t) * h(t) = \int_{-\infty}^{\infty} f(\tau) \cdot h(t - \tau) d\tau$$

- 令 $f(t)$ 、 $h(t)$ 、 $f(t) * h(t)$ 、 $f(t) \cdot h(t)$ 的傅里叶变换分别为 $F(u)$ 、 $H(u)$ 、 $G(u)$ 、 $J(u)$ ，可以证明：

- ✓ 空域（时域）卷积等价于频域乘积

$$G(u) = F(u) \cdot H(u)$$

- ✓ 空域（时域）乘积等价于频域卷积

$$J(u) = F(u) * H(u)$$

- 上述结论可以推广到二维情况

4.1 傅立叶变换基础： 取样

□ 将连续函数转换为离散序列

$$s_{\Delta T}(t) = \sum_{-\infty}^{\infty} \delta(t - n \cdot \Delta T)$$

ΔT 为冲激串的间隔

问题：如何选择
采样间隔？

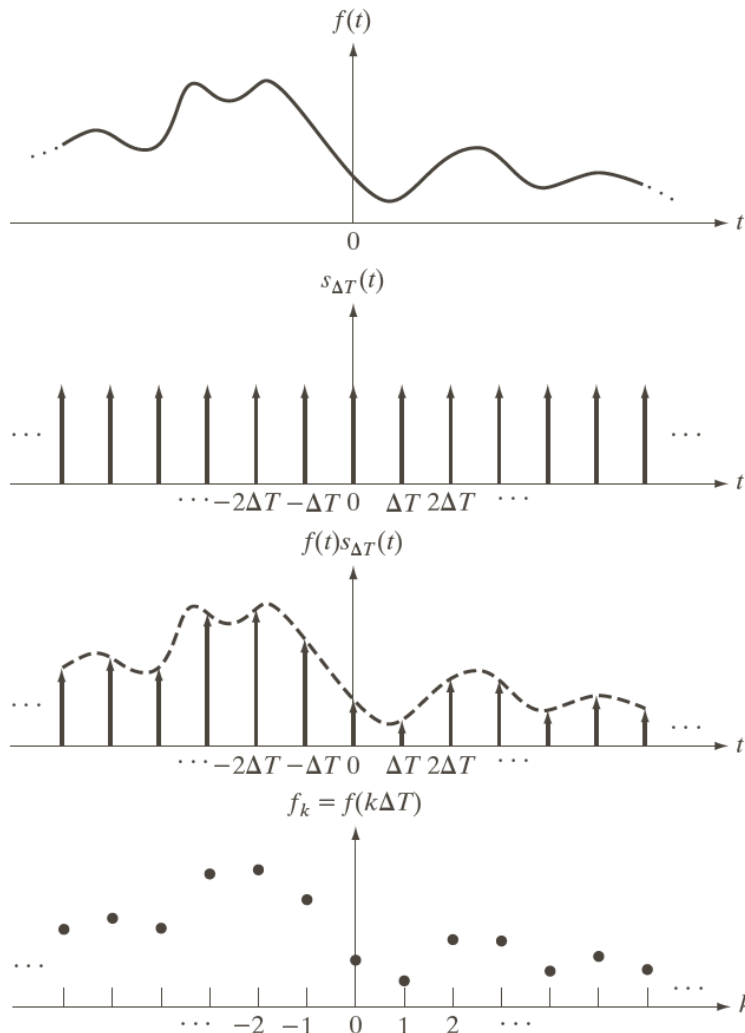

a
b
c
d

FIGURE 4.5
 (a) A continuous function. (b) Train of impulses used to model the sampling process. (c) Sampled function formed as the product of (a) and (b). (d) Sample values obtained by integration and using the sifting property of the impulse. (The dashed line in (c) is shown for reference. It is not part of the data.)



4.1 傅立叶变换基础：取样

□ 取样函数的傅里叶变换

- 空域（时域）卷积等价于频域乘积
- **奈奎斯特采样率：**完全等于信号最高频率的两倍的取样率。

$$S(\mu) = \frac{1}{\Delta T} \sum_{-\infty}^{\infty} \delta(\mu - \frac{n}{\Delta T})$$

$$\begin{aligned} \tilde{F}(\mu) &= F(u) * S(\mu) \\ &= \frac{1}{\Delta T} \sum_{-\infty}^{\infty} F(\mu - \frac{n}{\Delta T}) \end{aligned}$$

ΔT 为冲激串的间隔

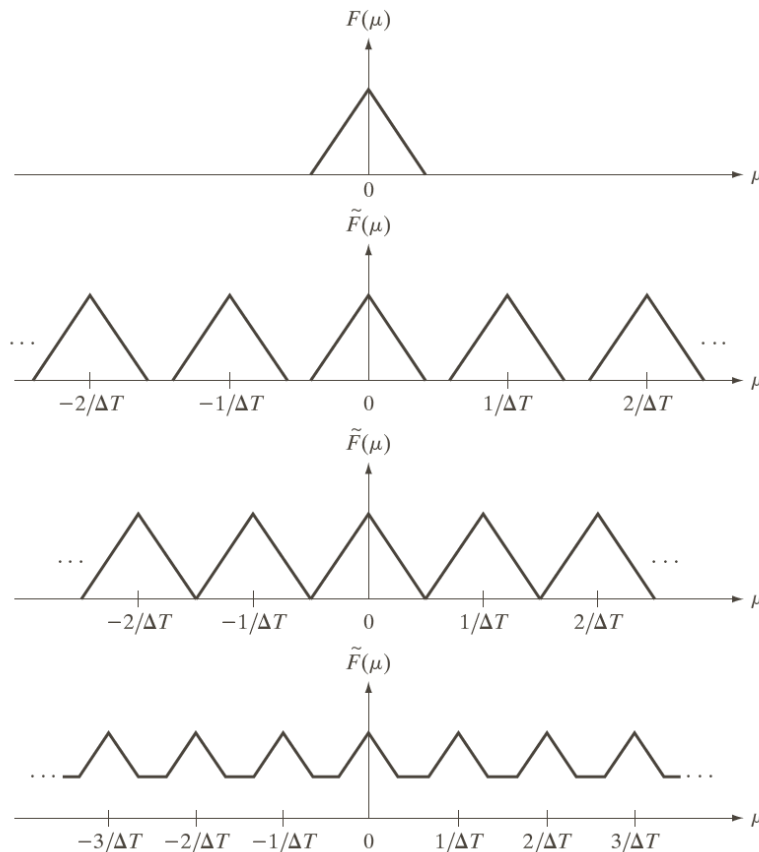

a
b
c
d

FIGURE 4.6 (a) Fourier transform of a band-limited function. (b)–(d) Transforms of the corresponding sampled function under the conditions of over-sampling, critically-sampling, and under-sampling, respectively.

取样定理：当以超过奈奎斯特采样率来获取样本，则连续带限函数能完全由其样本集恢复。

低通滤波提取带限信号

- 通过理想低通滤波器可以复原 $F(\mu)$
 - 但理想低通滤波器的**幅度快速过渡特性**用物理电子元件无法实现
 - 可以用软件来模拟理想低通滤波器

a
b
c

FIGURE 4.8

(a) Fourier transform of a sampled, band-limited function.
(b) Ideal lowpass filter transfer function.
(c) The product of (b) and (a), used to extract one period of the infinitely periodic sequence in (a).

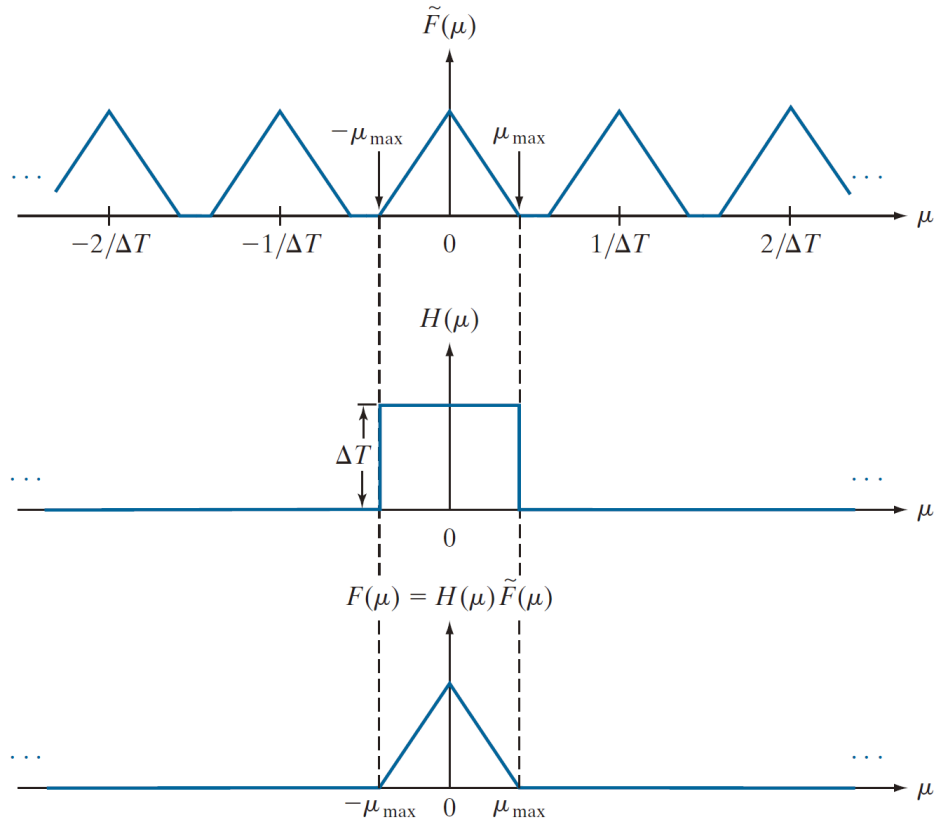

混淆

□ 对一个带限函数，以低于奈奎斯特采样率进行采样，结果会出现**频率混淆**

来自邻近周期的频率分量的干扰导致了混淆，妨碍 $F(\mu)$ 的完美复原

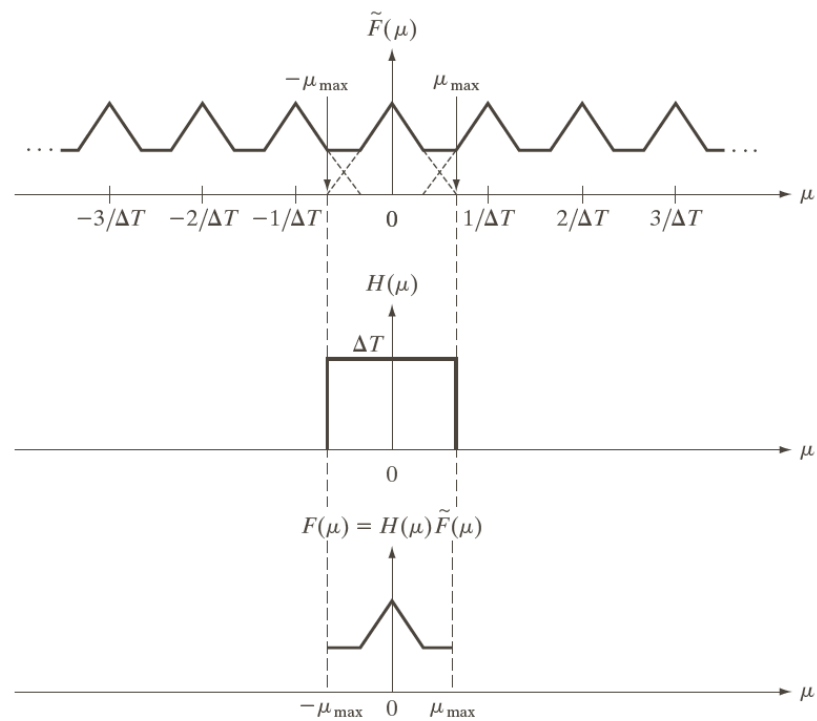

a
b
c

FIGURE 4.9 (a) Fourier transform of an under-sampled, band-limited function. (Interference from adjacent periods is shown dashed in this figure). (b) The same ideal lowpass filter used in Fig. 4.8(b). (c) The product of (a) and (b). The interference from adjacent periods results in aliasing that prevents perfect recovery of $F(\mu)$ and, therefore, of the original, band-limited continuous function. Compare with Fig. 4.8.

混淆

- 实例：采样频率低于原始信号频率的两倍
 - 取样后的信号看上去像正弦波，但其频率是原始信号的十分之一
 - 混淆的严重程度使得我们无法知道这些样本是不是原始函数的真实描述

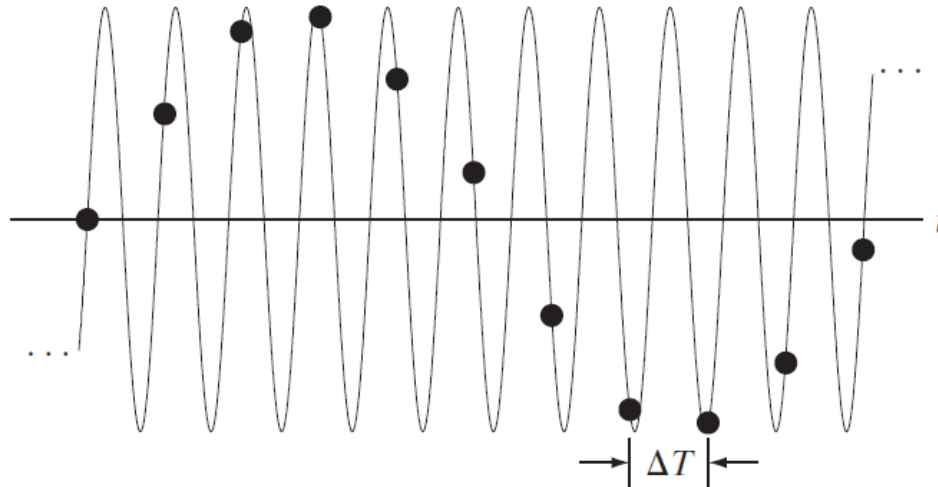
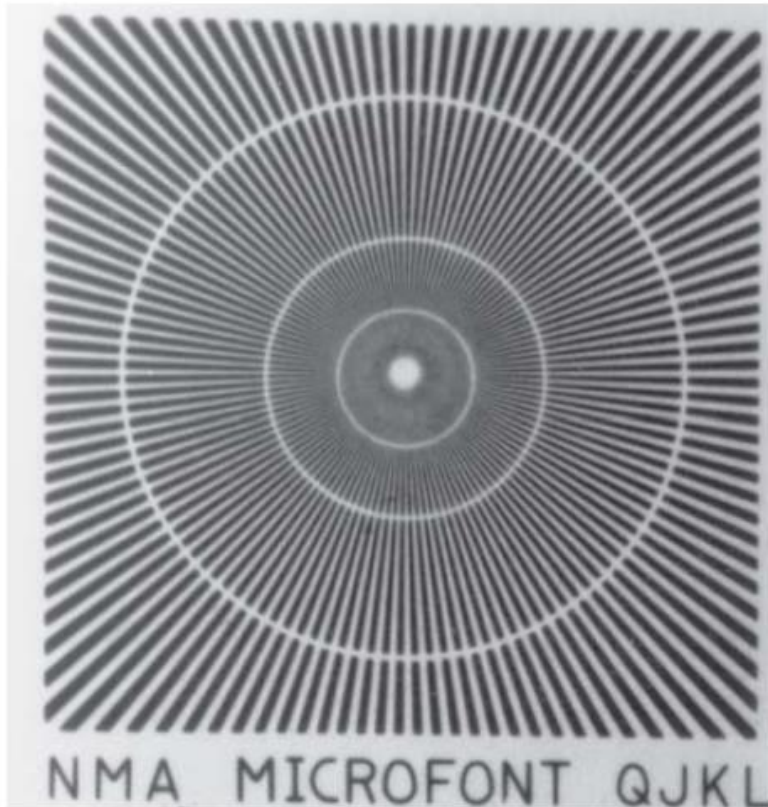

FIGURE 4.10 Illustration of aliasing. The under-sampled function (black dots) looks like a sine wave having a frequency much lower than the frequency of the continuous signal. The period of the sine wave is 2 s, so the zero crossings of the horizontal axis occur every second. ΔT is the separation between samples.

数字图像中的混淆

□ 二维欠采样造成的空间混淆



(a) Original image

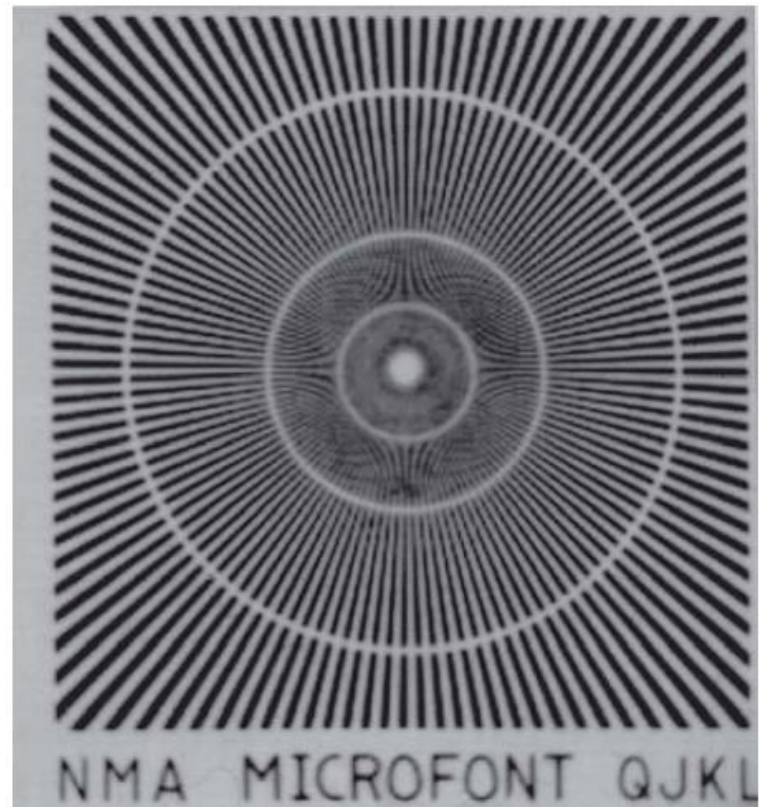

(b) Sampled image

数字图像中的混淆

□ 图像内插和重采样

- 完美重建需要用sinc函数在空间做二维卷积，涉及无限求和
 - ✓ 盒状滤波器的傅里叶反变换是sinc函数
- 实践中采用近似方式：放大可视为过采样，缩写可视为欠采样



a b c

重取样后的图像上的混淆的说明: (a)带有视觉上可以忽略的混淆的数字图像; (b)采用行-列删除法将图像尺寸缩小到其原始尺寸 50%后的结果。混淆清晰可见; (c)在调整图像大小之前, 使用一个 3x3均值滤波器来模糊(a)中图像的结果。该图像比图(b)更模糊, 但混淆不再那样显眼。

数字图像中的混淆

□ 图像内插和重采样

■ 图像缩小产生的锯齿现象

- ✓ 在缩小前，使用均值滤波，可减少锯齿

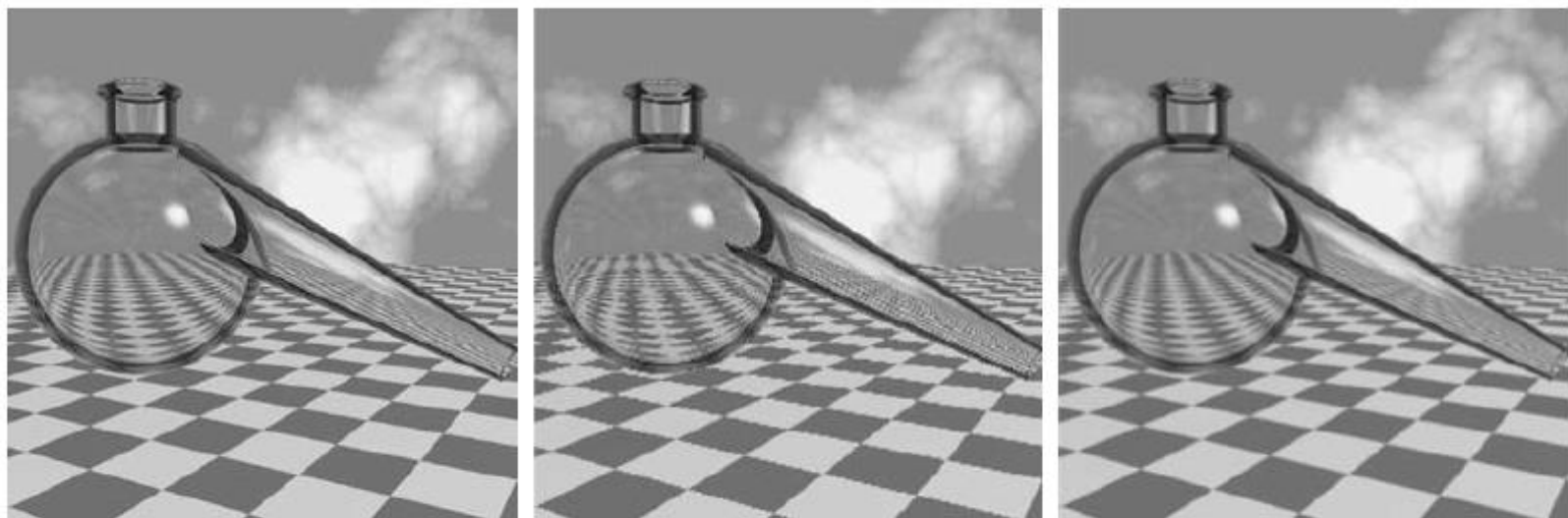

a b c

FIGURE 4.18 Illustration of jaggies. (a) A 1024×1024 digital image of a computer-generated scene with negligible visible aliasing. (b) Result of reducing (a) to 25% of its original size using bilinear interpolation. (c) Result of blurring the image in (a) with a 5×5 averaging filter prior to resizing it to 25% using bilinear interpolation. (Original image courtesy of D. P. Mitchell, Mental Landscape, LLC.)

数字图像中的混淆

- 图像内插和重采样
 - 图像放大产生的锯齿现象

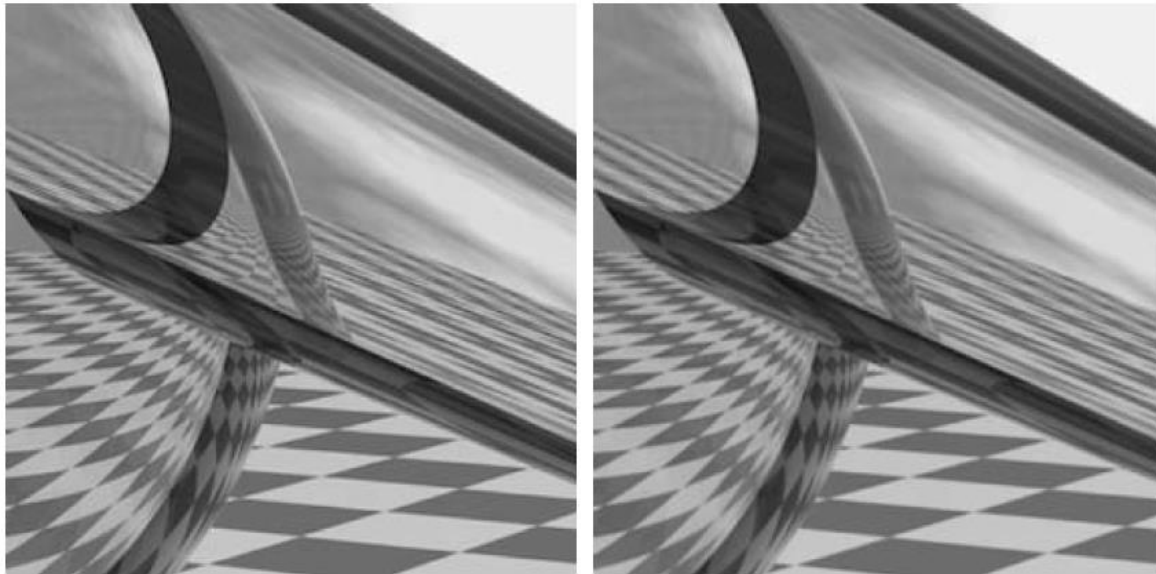

a b

FIGURE 4.19 Image zooming. (a) A 1024×1024 digital image generated by pixel replication from a 256×256 image extracted from the middle of Fig. 4.18(a). (b) Image generated using bi-linear interpolation, showing a significant reduction in jaggies.



4.1 傅立叶变换基础

□ 傅里叶变换 (FT)、离散时间傅里叶变换 (DTFT) 和离散傅里叶变换 (DFT) 之间的关系

■ DFT: 对一个周期取样

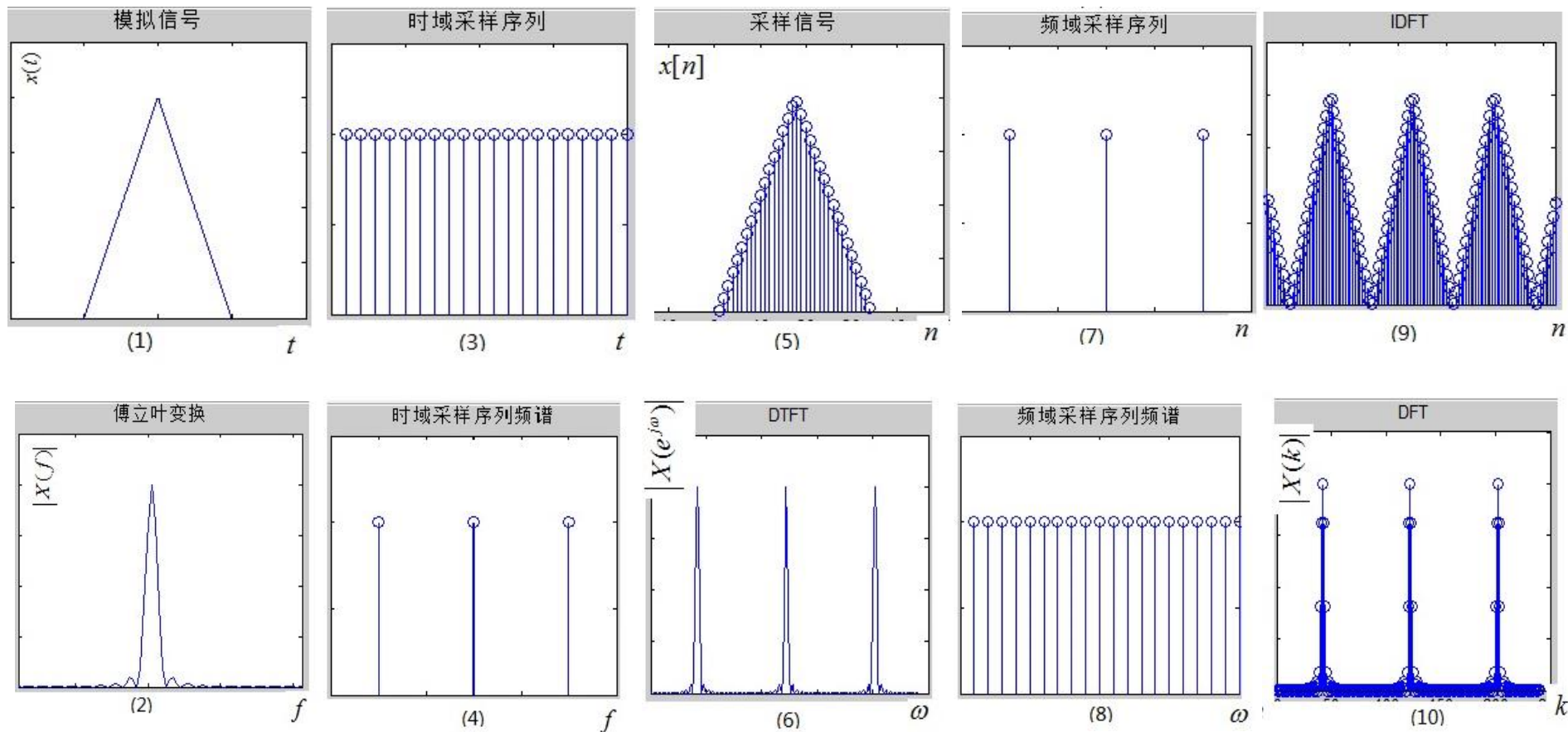



4.1 离散傅立叶变换(DFT)

二维DFT及其反变换

一个图像关于的函数的离散

$$F(u, v) = \sum_{x=0}^{M-1} \sum_{y=0}^{N-1} f(x, y) e^{-j2\pi(ux/M + vy/N)}$$

$$u = 0.1.2.\dots M - 1$$

$$v = 0.1.2.\dots N - 1$$

$$f(x, y) = \frac{1}{MN} \sum_{u=0}^{M-1} \sum_{v=0}^{N-1} F(u, v) e^{j2\pi(ux/M + vy/N)}$$

$$x = 0.1.2.\dots M - 1$$

$$y = 0.1.2.\dots N - 1$$

傅里叶谱: $|F(u, v)| = \left[R^2(x, y) + I^2(x, y) \right]^{\frac{1}{2}}$

相角: $\phi(u, v) = \tan^{-1} \left[\frac{I(u, v)}{R(u, v)} \right]$



4.1 离散傅立叶变换(DFT)

□ 二维DFT及其反变换

功率谱:

$$P(u, v) = |F(u, v)|^2 = R^2(u, v) + I^2(u, v)$$

可以证明:

$$\mathcal{D}\left[f(x, y)(-1)^{x+y}\right] = F\left(u - \frac{M}{2}, v - \frac{N}{2}\right)$$

相当于原点被放置在 $u = \frac{M}{2}, v = \frac{N}{2}$ 上

$$F(0, 0) = MN \frac{1}{MN} \sum_{x=0}^{M-1} \sum_{y=0}^{N-1} f(x, y) = MN \bar{f}$$

\bar{f} 为图象平均灰度。



2D DFT及其反变换的一些性质

Spatial Domain [†]		Frequency Domain [†]	
1)	$f(x, y)$ real	\Leftrightarrow	$F^*(u, v) = F(-u, -v)$
2)	$f(x, y)$ imaginary	\Leftrightarrow	$F^*(-u, -v) = -F(u, v)$
3)	$f(x, y)$ real	\Leftrightarrow	$R(u, v)$ even; $I(u, v)$ odd
4)	$f(x, y)$ imaginary	\Leftrightarrow	$R(u, v)$ odd; $I(u, v)$ even
5)	$f(-x, -y)$ real	\Leftrightarrow	$F^*(u, v)$ complex
6)	$f(-x, -y)$ complex	\Leftrightarrow	$F(-u, -v)$ complex
7)	$f^*(x, y)$ complex	\Leftrightarrow	$F^*(-u - v)$ complex
8)	$f(x, y)$ real and even	\Leftrightarrow	$F(u, v)$ real and even
9)	$f(x, y)$ real and odd	\Leftrightarrow	$F(u, v)$ imaginary and odd
10)	$f(x, y)$ imaginary and even	\Leftrightarrow	$F(u, v)$ imaginary and even
11)	$f(x, y)$ imaginary and odd	\Leftrightarrow	$F(u, v)$ real and odd
12)	$f(x, y)$ complex and even	\Leftrightarrow	$F(u, v)$ complex and even
13)	$f(x, y)$ complex and odd	\Leftrightarrow	$F(u, v)$ complex and odd

TABLE 4.1 Some symmetry properties of the 2-D DFT and its inverse. $R(u, v)$ and $I(u, v)$ are the real and imaginary parts of $F(u, v)$, respectively. The term *complex* indicates that a function has nonzero real and imaginary parts.

[†]Recall that x, y, u , and v are *discrete* (integer) variables, with x and u in the range $[0, M - 1]$, and y , and v in the range $[0, N - 1]$. To say that a complex function is *even* means that its real *and* imaginary parts are even, and similarly for an odd complex function.



二维DFT的性质

- **线性** $f_1(x, y) + f_2(x, y)$ $F_1(u, v) + F_2(u, v)$
- **比例** $f(ax, by)$ $\frac{1}{ab} F\left(\frac{u}{a}, \frac{v}{b}\right)$
- **平移** $f(x - a, y - b)$ $e^{-j2\pi(au+bv)} F(u, v)$
 $e^{j2\pi(cx+dy)} f(x, y)$ $F(u - c, v - d)$
- **卷积** $f_1(x, y) * f_2(x, y)$ $F_1(u, v)F_2(u, v)$
 $f_1(x, y)f_2(x, y)$ $F_1(u, v) * F_2(u, v)$
- **旋转** $f(x \cos \theta + y \sin \theta, -x \sin \theta + y \cos \theta)$
 $F(u \cos \theta + v \sin \theta, -u \sin \theta + v \cos \theta)$

2D DFT的性质：周期性

$$\mathcal{F}\left[f(x, y)(-1)^{x+y}\right] = F\left(u - \frac{M}{2}, v - \frac{N}{2}\right)$$

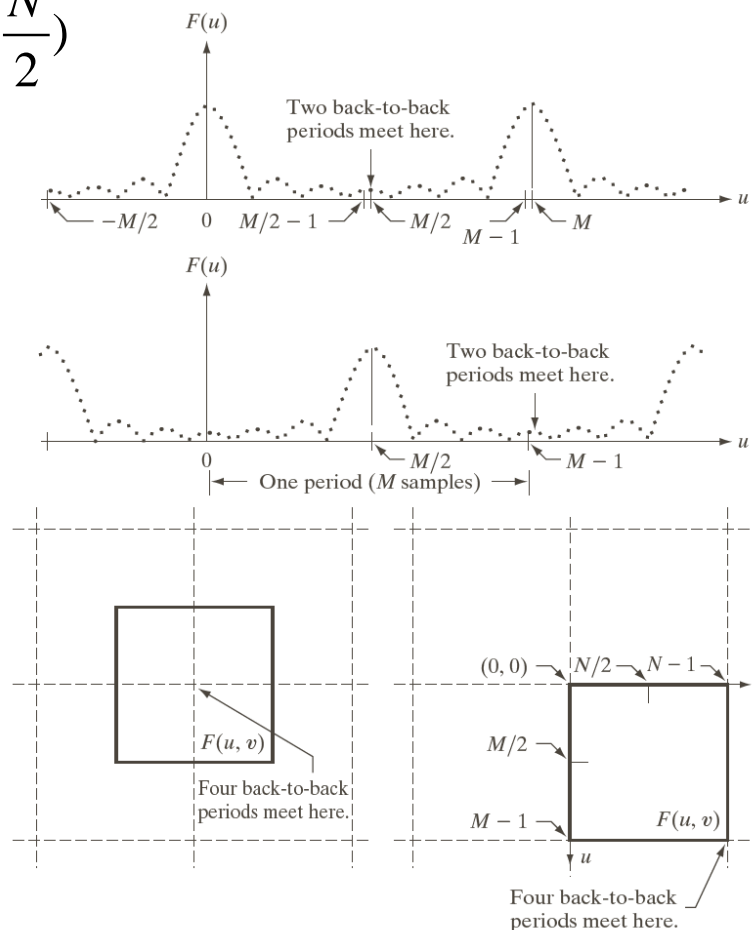

a
b
c d

FIGURE 4.23 Centering the Fourier transform. (a) A 1-D DFT showing an infinite number of periods. (b) Shifted DFT obtained by multiplying $f(x)$ by $(-1)^x$ before computing $F(u)$. (c) A 2-D DFT showing an infinite number of periods. The solid area is the $M \times N$ data array, $F(u, v)$, obtained with Eq. (4.5-15). This array consists of four quarter periods. (d) A Shifted DFT obtained by multiplying $f(x, y)$ by $(-1)^{x+y}$ before computing $F(u, v)$. The data now contains one complete, centered period, as in (b).

\square = Periods of the DFT.
 \blacksquare = $M \times N$ data array, $F(u, v)$.

数字图像的DFT变换

□ 傅里叶谱图的中心化平移和对数增强

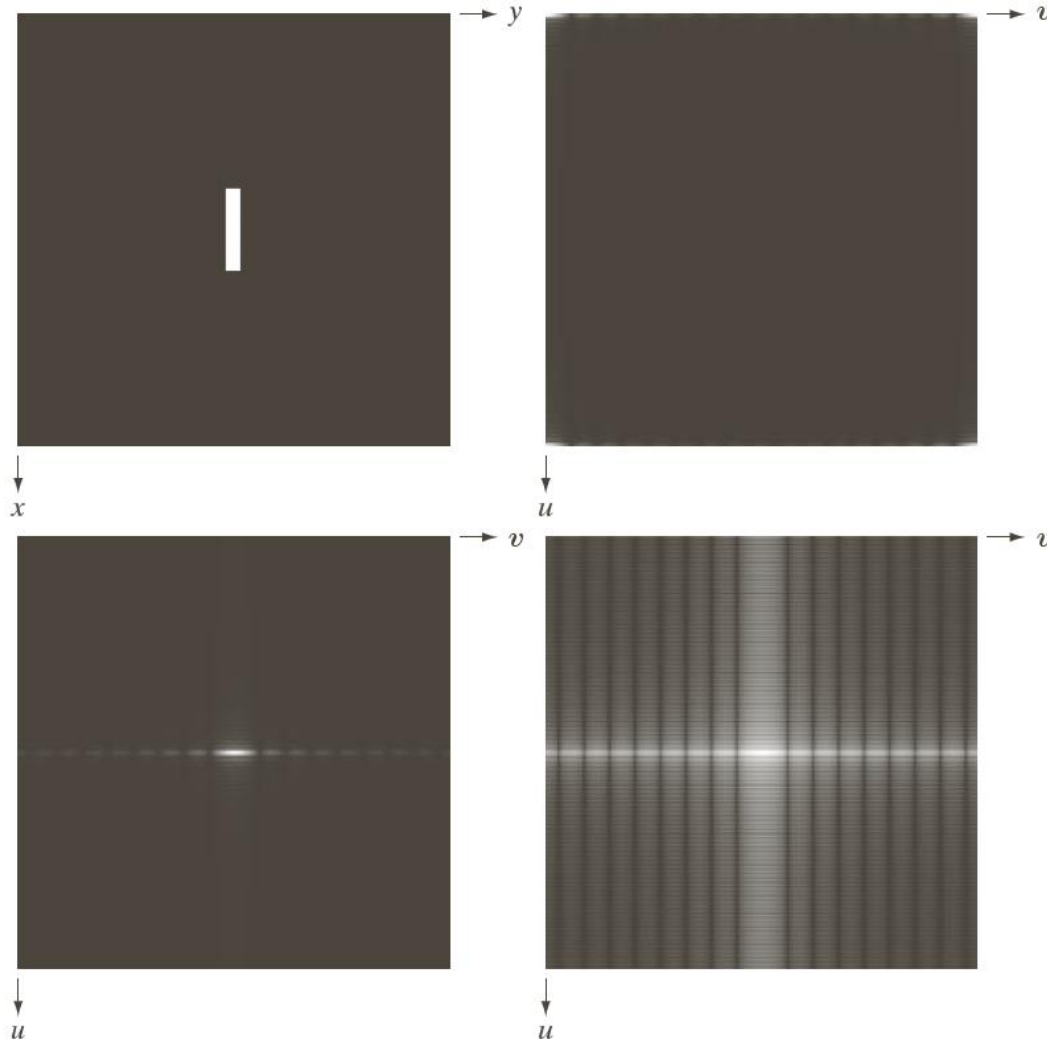

a b
c d

FIGURE 4.24
(a) Image.
(b) Spectrum showing bright spots in the four corners.
(c) Centered spectrum.
(d) Result showing increased detail after a log transformation. The zero crossings of the spectrum are closer in the vertical direction because the rectangle in (a) is longer in that direction. The coordinate convention used throughout the book places the origin of the spatial and frequency domains at the top left.

数字图像的DFT变换

二维DFT及其反变换

下图实例:

中心化, 矩形宽高化为 2 : 1
反映到频域轴亮点间距恰好相反

$$f(ax, by) \longleftrightarrow \frac{1}{ab} F\left(\frac{u}{a}, \frac{v}{b}\right)$$

a b

FIGURE 4.3

(a) Image of a 20×40 white rectangle on a black background of size 512×512 pixels.
(b) Centered Fourier spectrum shown after application of the log transformation given in Eq. (3.2-2). Compare with Fig. 4.2.

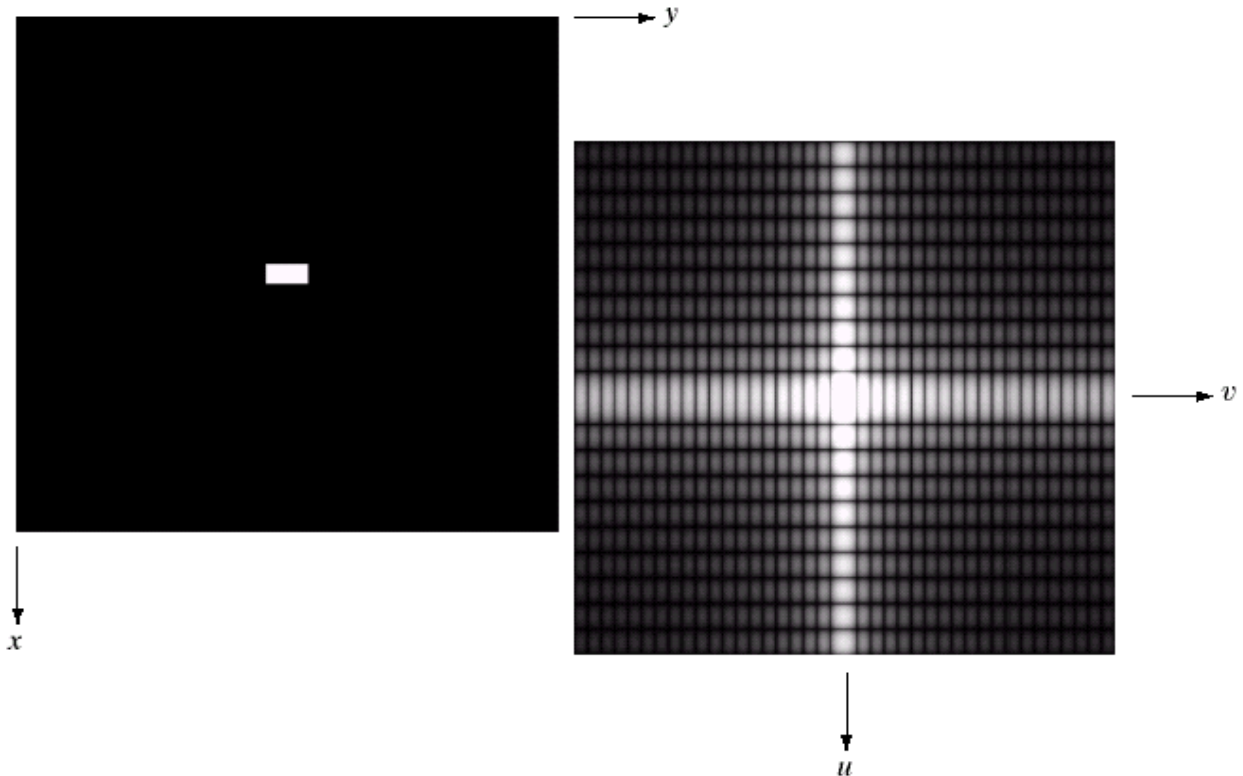

数字图像的DFT变换

- 图像的傅里叶谱对旋转不敏感；其会随旋转图像以相同的角度旋转

a b
c d

FIGURE 4.25

(a) The rectangle in Fig. 4.24(a) translated, and (b) the corresponding spectrum. (c) Rotated rectangle, and (d) the corresponding spectrum. The spectrum corresponding to the translated rectangle is identical to the spectrum corresponding to the original image in Fig. 4.24(a).

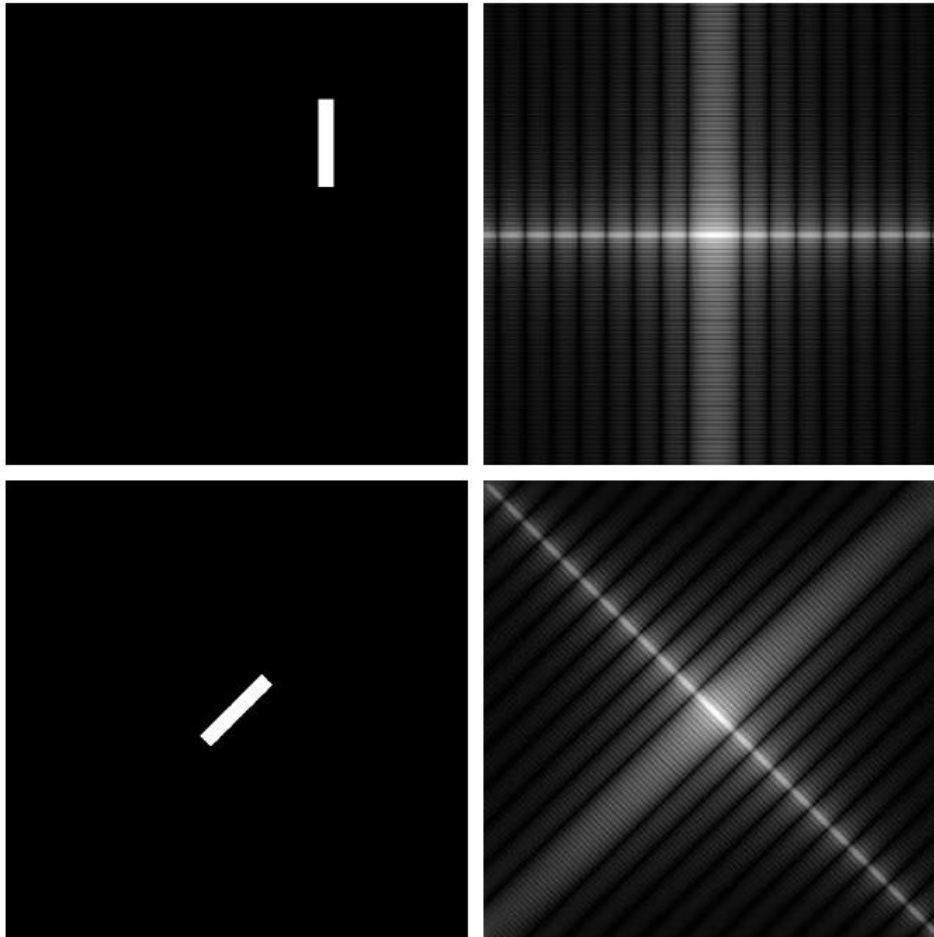

$$f(x-a, y-b) \leftrightarrow e^{-j2\pi(au+bv)} F(u, v)$$

$$f(x \cos \theta + y \sin \theta, -x \sin \theta + y \cos \theta)$$



$$F(u \cos \theta + v \sin \theta, -u \sin \theta + v \cos \theta)$$

数字图像的DFT变换

- 图像发生平移或旋转变换后，对应相角发生变化
 - 缺少直观的类比性
 - 相角携带了反映图像中物体空间位置的信息

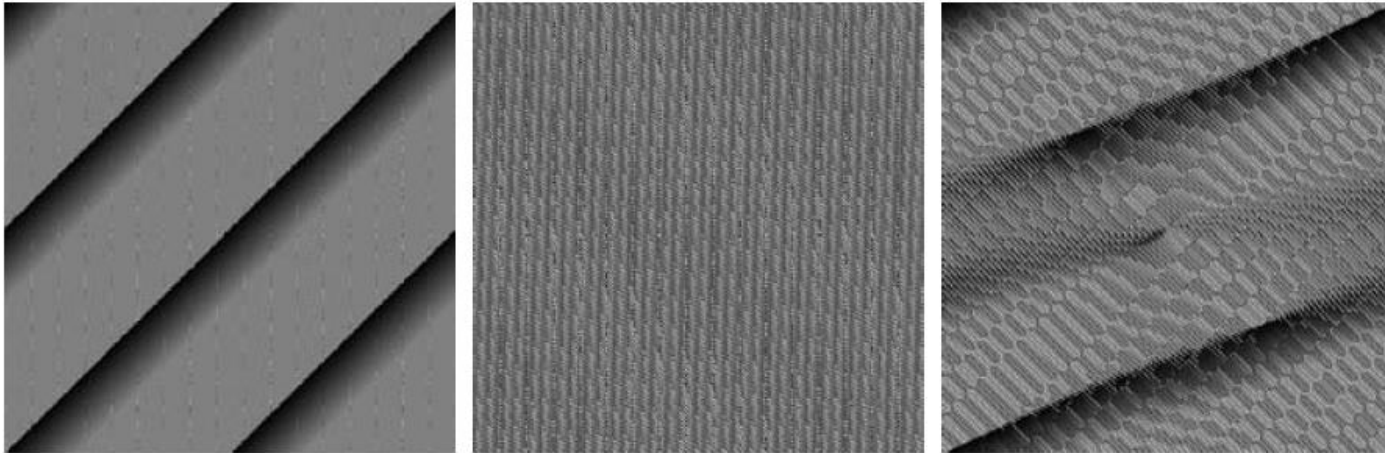

a b c

FIGURE 4.26 Phase angle array corresponding (a) to the image of the centered rectangle in Fig. 4.24(a), (b) to the translated image in Fig. 4.25(a), and (c) to the rotated image in Fig. 4.25(c).

基于二维DFT频谱与相位的反变换

- 仅用相角信息，可恢复原图的**关键形状特性**
- 仅用谱信息，直流项占支配地位，难以恢复原图的形状信息

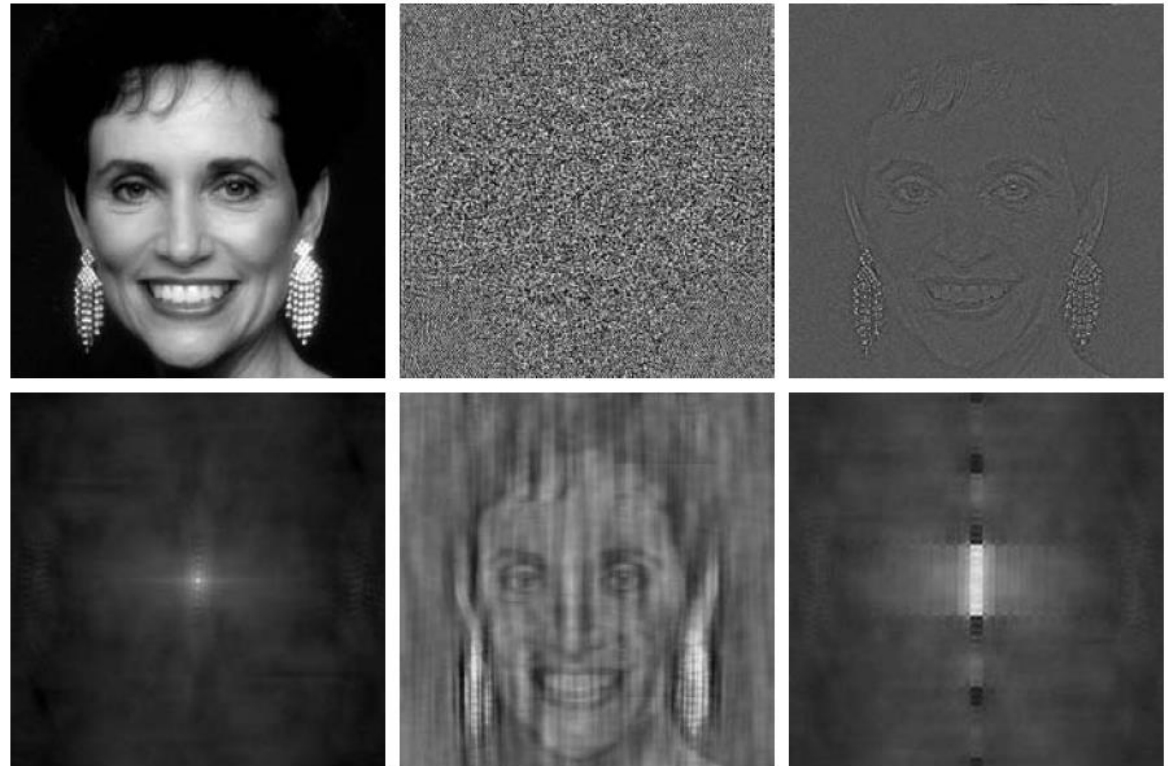

a b c
d e f

FIGURE 4.27 (a) Woman. (b) Phase angle. (c) Woman reconstructed using only the phase angle. (d) Woman reconstructed using only the spectrum. (e) Reconstruction using the phase angle corresponding to the woman and the spectrum corresponding to the rectangle in Fig. 4.24(a). (f) Reconstruction using the phase of the rectangle and the spectrum of the woman.

数字图像的DFT变换

线性叠加及尺度变化

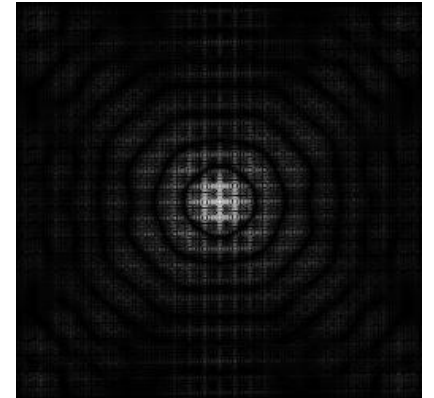
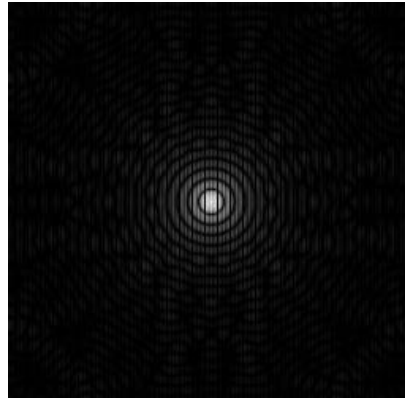
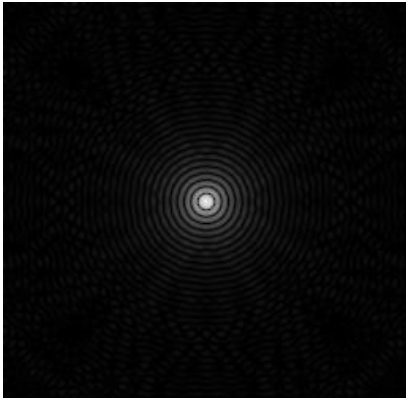
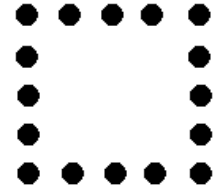

数字图像的DFT变换

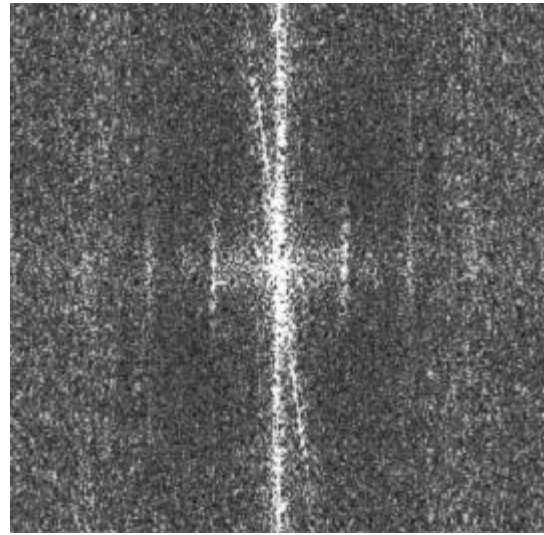

数字图像的DFT变换

典型图象的频谱

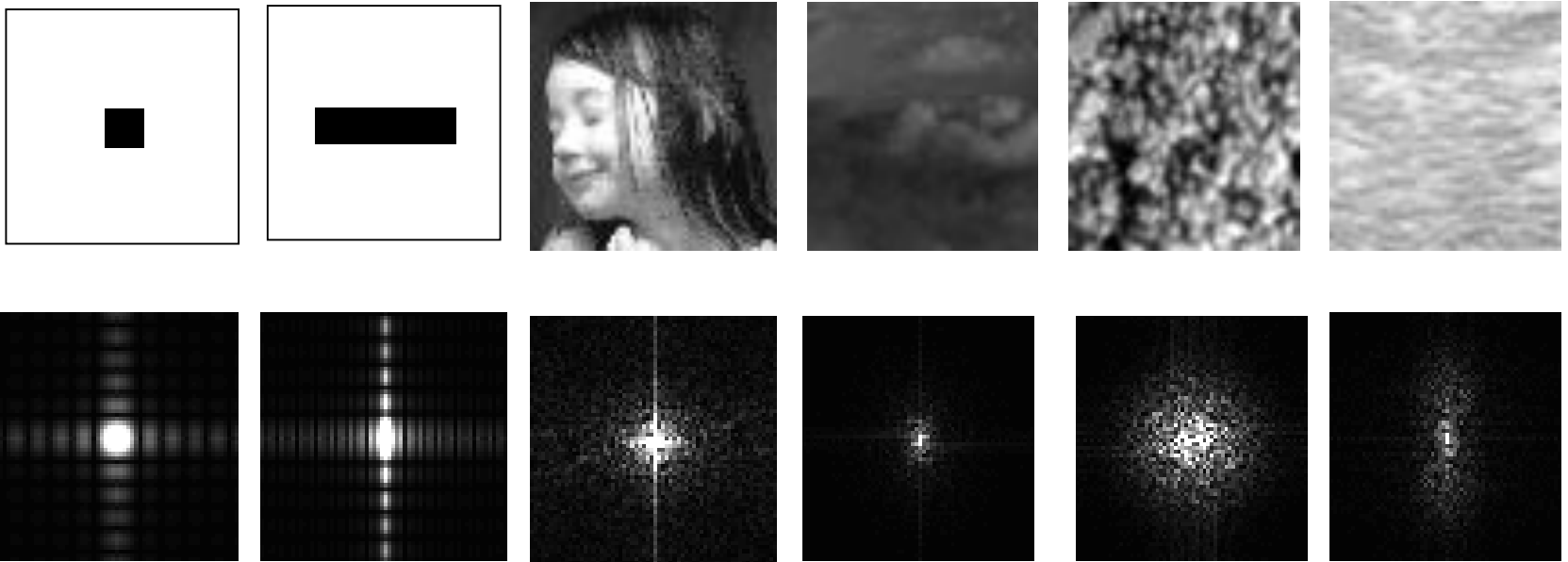



二维卷积定理

□ 二维卷积定理

$$f(x, y) \star h(x, y) \Leftrightarrow F(u, v)H(u, v)$$

$$f(x, y)h(x, y) \Leftrightarrow F(u, v) \star H(u, v)$$

□ 在实际编程实现时，需注意上述等价性的前提条件

- DFT变换时， $f(x, y)$ 和 $F(u, v)$ 的大小相同，均为 $M \times N$
- 二维DFT及其反变换结果均为无限周期

$$F(u, v) = F(u + k_1M, v + k_2N)$$

$$f(x, y) = f(x + k_1M, y + k_2N)$$

- 如果希望通过先做频域乘积、再对结果进行DFT反变换，来实现空域卷积，则需要保证信号**无缠绕**
 - ✓ 可通过将原始数字信号通过补零，延拓其矩阵大小

二维卷积定理：空域卷积 vs. DFT

□ DFT变换时， $f(x, y)$ 和 $F(u, v)$ 的大小相同，均为 $M \times N$

$$f(x, y) \star h(x, y) = \sum_{m=0}^{M-1} \sum_{n=0}^{N-1} f(m, n)h(x - m, y - n)$$

$$f(x) \star h(x) = \sum_{m=0}^{399} f(x)h(x - m)$$

解决缠绕错误：添加0补齐

$$P \geq A + B - 1$$

$$P=400+400-1=799$$

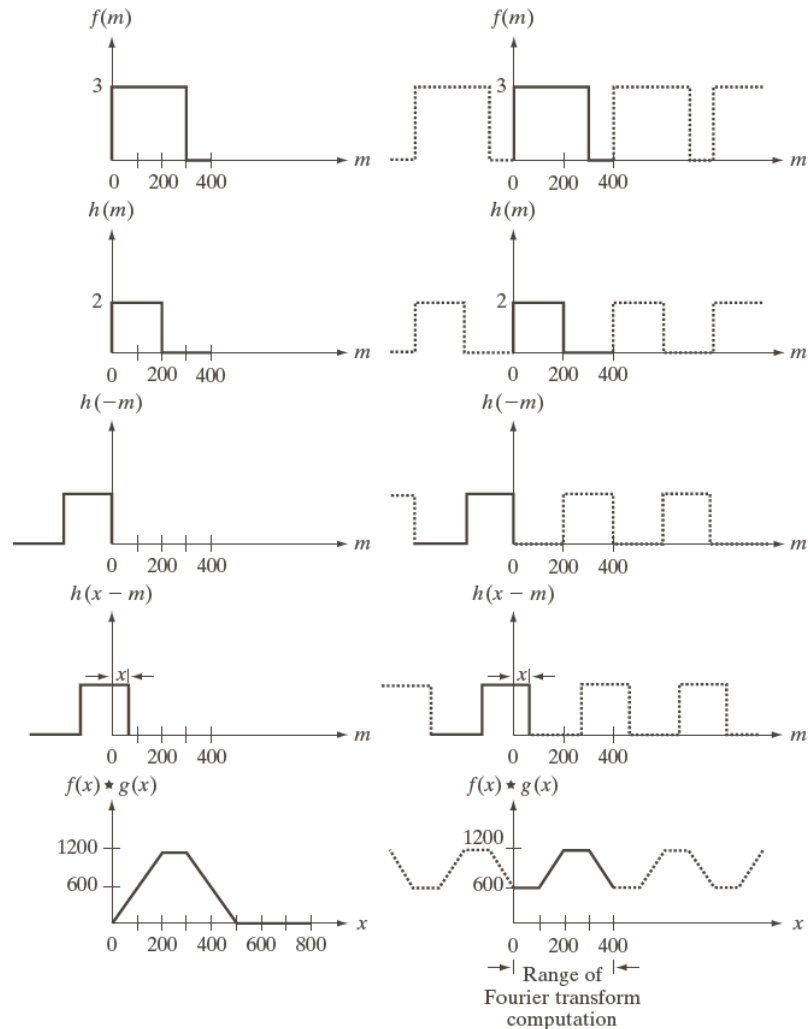

a	f
b	g
c	h
d	i
e	j

FIGURE 4.28 Left column: convolution of two discrete functions obtained using the approach discussed in Section 3.4.2. The result in (e) is correct. Right column: Convolution of the same functions, but taking into account the periodicity implied by the DFT. Note in (j) how data from adjacent periods produce wraparound error, yielding an incorrect convolution result. To obtain the correct result, function padding must be used.



DFT定义及相关表达式小结

Name	Expression(s)
1) Discrete Fourier transform (DFT) of $f(x, y)$	$F(u, v) = \sum_{x=0}^{M-1} \sum_{y=0}^{N-1} f(x, y) e^{-j2\pi(ux/M+vy/N)}$
2) Inverse discrete Fourier transform (IDFT) of $F(u, v)$	$f(x, y) = \frac{1}{MN} \sum_{u=0}^{M-1} \sum_{v=0}^{N-1} F(u, v) e^{j2\pi(ux/M+vy/N)}$
3) Polar representation	$F(u, v) = F(u, v) e^{j\phi(u, v)}$
4) Spectrum	$ F(u, v) = [R^2(u, v) + I^2(u, v)]^{1/2}$ $R = \text{Real}(F); \quad I = \text{Imag}(F)$
5) Phase angle	$\phi(u, v) = \tan^{-1} \left[\frac{I(u, v)}{R(u, v)} \right]$
6) Power spectrum	$P(u, v) = F(u, v) ^2$
7) Average value	$\bar{f}(x, y) = \frac{1}{MN} \sum_{x=0}^{M-1} \sum_{y=0}^{N-1} f(x, y) = \frac{1}{MN} F(0, 0)$

(Continued)



DFT定义及相关表达式小结

8) Periodicity (k_1 and k_2 are integers)

$$\begin{aligned} F(u, v) &= F(u + k_1M, v) = F(u, v + k_2N) \\ &= F(u + k_1M, v + k_2N) \end{aligned}$$

$$\begin{aligned} f(x, y) &= f(x + k_1M, y) = f(x, y + k_2N) \\ &= f(x + k_1M, y + k_2N) \end{aligned}$$

9) Convolution

$$f(x, y) \star h(x, y) = \sum_{m=0}^{M-1} \sum_{n=0}^{N-1} f(m, n)h(x - m, y - n)$$

10) Correlation

$$f(x, y) \star\star h(x, y) = \sum_{m=0}^{M-1} \sum_{n=0}^{N-1} f^*(m, n)h(x + m, y + n)$$

11) Separability

The 2-D DFT can be computed by computing 1-D DFT transforms along the rows (columns) of the image, followed by 1-D transforms along the columns (rows) of the result. See Section 4.11.1.

12) Obtaining the inverse Fourier transform using a forward transform algorithm.

$$MNf^*(x, y) = \sum_{u=0}^{M-1} \sum_{v=0}^{N-1} F^*(u, v)e^{-j2\pi(ux/M+vy/N)}$$

This equation indicates that inputting $F^*(u, v)$ into an algorithm that computes the forward transform (right side of above equation) yields $MNf^*(x, y)$. Taking the complex conjugate and dividing by MN gives the desired inverse. See Section 4.11.2.



第4章 频率域滤波

- 4.1 离散傅立叶变换(DFT)
- 4.2 频率域滤波基础
- 4.3 频率域滤波器平滑图像
- 4.4 频率域滤波器锐化图像
- 4.5 选择性滤波

4.2 频率域滤波基础

频率域滤波基本步骤:

- 1、 $(-1)^{x+y} \times$ 原图像
 - 2、 $F(u, v)$
 - 3、 $H(u, v) \times F(u, v)$
 - 4、 反DEF
 - 5、 实部
 - 6、 用 $(-1)^{x+y} \times$ (5) 结果。
- 被滤波图像 = $\mathcal{F}^{-1}[G(u, v)]$

$$G(u, v) = H(u, v)F(u, v)$$

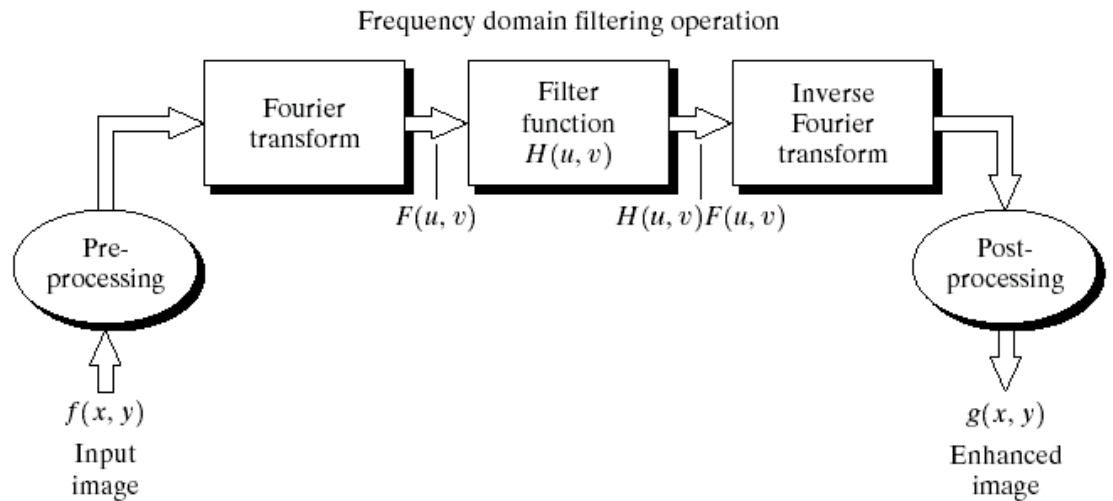
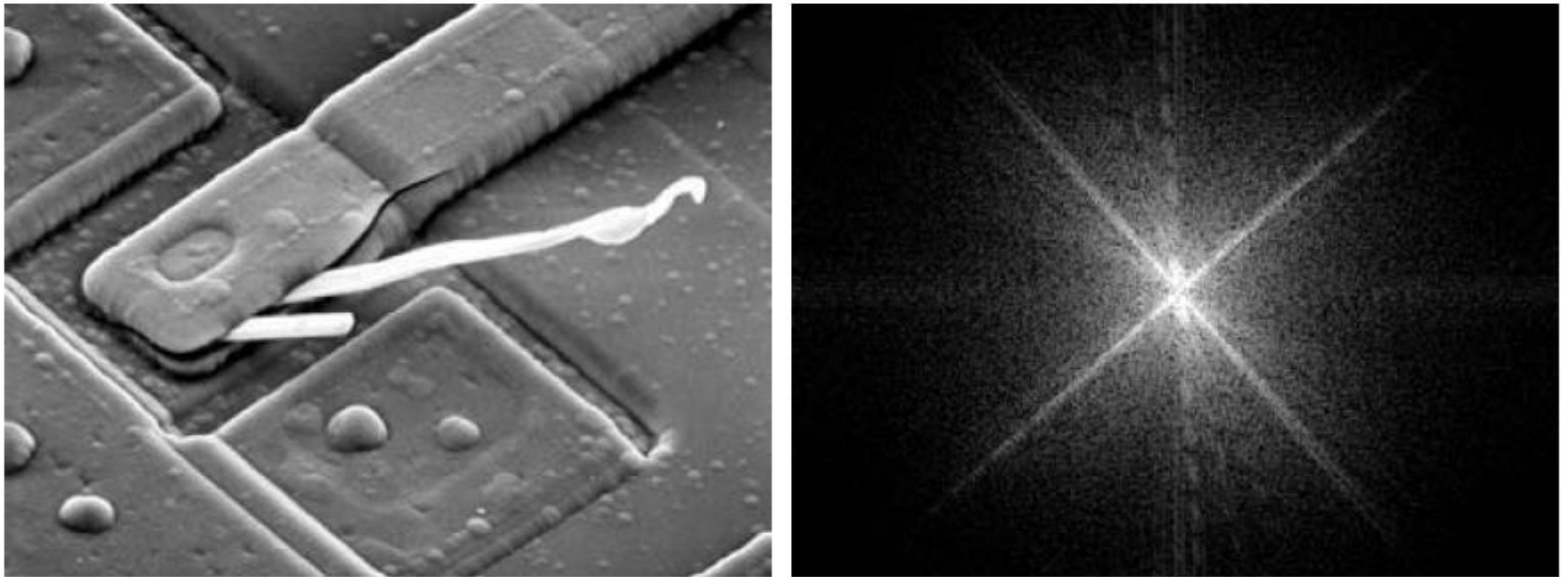

FIGURE 4.5 Basic steps for filtering in the frequency domain.

图像空域与频域的定性分析

□ 集成电路SEM图像及其傅里叶谱



a b

FIGURE 4.29 (a) SEM image of a damaged integrated circuit. (b) Fourier spectrum of (a). (Original image courtesy of Dr. J. M. Hudak, Brockhouse Institute for Materials Research, McMaster University, Hamilton, Ontario, Canada.)

4.2 频率域滤波基础

□ 一些基本的滤波器及其性质

陷波滤波器： $F(0,0) \rightarrow$ 平均值
如果想使其平均灰度为0，则可：

$$H(u, v) = \begin{cases} 0 & (u, v) = (\frac{M}{2}, \frac{N}{2}) \\ 1 & \text{其它} \end{cases}$$

具体见如下图示（负值被置为零）：

FIGURE 4.6
Result of filtering
the image in
Fig. 4.4(a) with a
notch filter that
set to 0 the
 $F(0, 0)$ term in
the Fourier
transform.

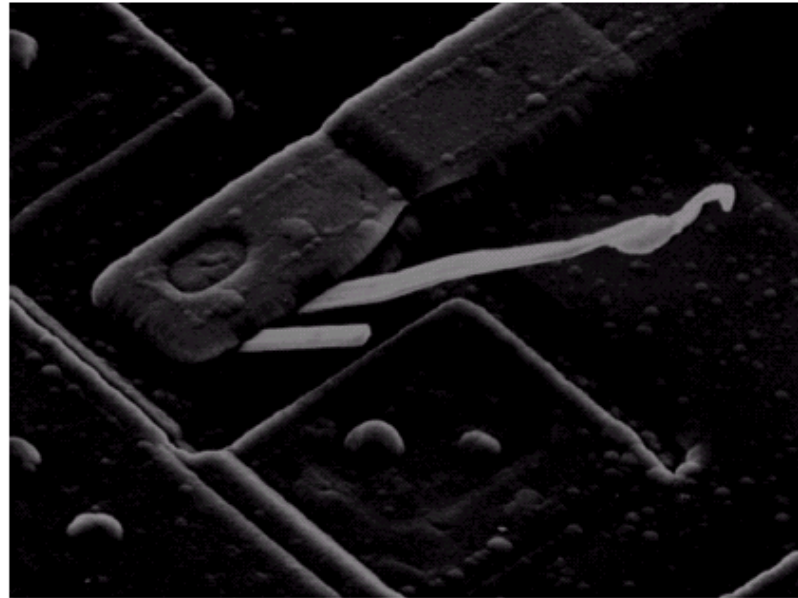

4.2 频率域滤波基础

□ 高通滤波与低通滤波

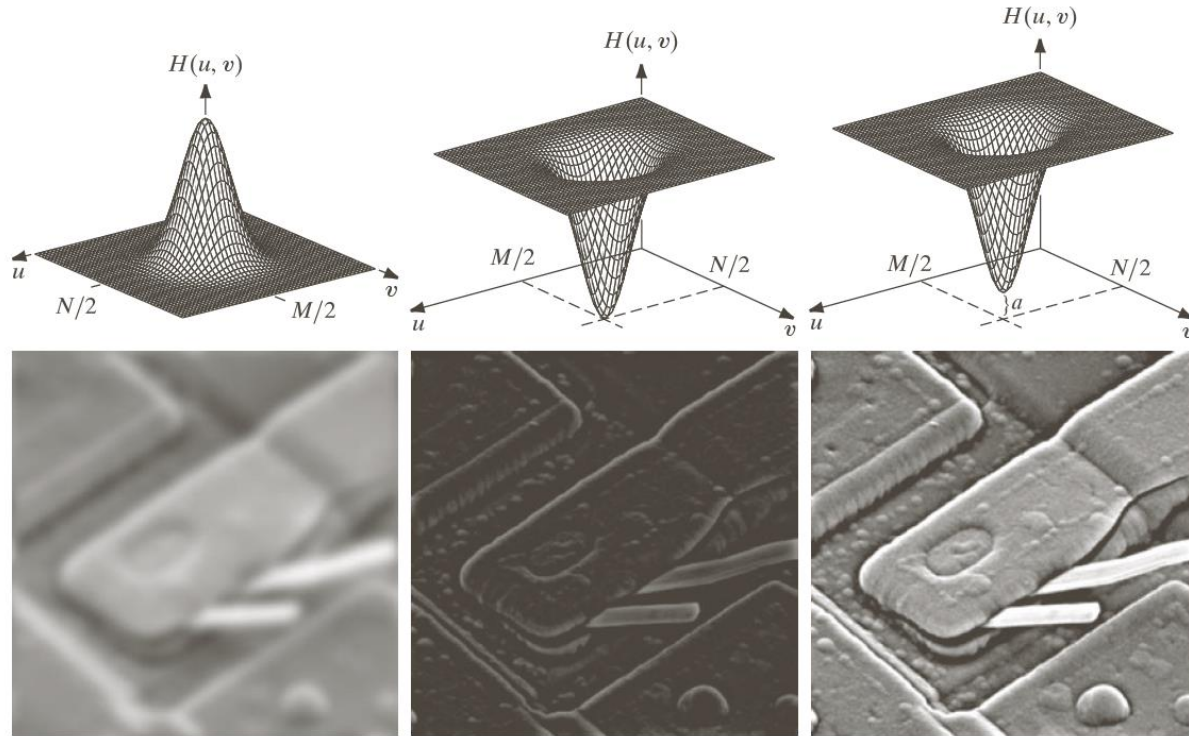

a	b	c
d	e	f

FIGURE 4.31 Top row: frequency domain filters. Bottom row: corresponding filtered images obtained using Eq. (4.7-1). We used $a = 0.85$ in (c) to obtain (f) (the height of the filter itself is 1). Compare (f) with Fig. 4.29(a).

使用DFT时二维图像固有的周期性

□ 边缘填充对滤波结果的影响

- 由于DFT的固有周期性，“先频率低通滤波、后反变换回空域”等价于“在空域对图像矩阵的周期性信号进行空域卷积滤波”
- 为了避免信号出现混叠，需要在图像的空域信号矩阵进行补零边缘延拓



a b c

FIGURE 4.32 (a) A simple image. (b) Result of blurring with a Gaussian lowpass filter without padding. (c) Result of lowpass filtering with padding. Compare the light area of the vertical edges in (b) and (c).

使用DFT时二维图像固有的周期性

□ 边缘填充对滤波结果的影响

- 由于DFT的固有周期性，“先频率低通滤波、后反变换回空域”等价于“在空域对图像矩阵的周期性信号进行空域卷积滤波”
- 为了避免信号出现混叠，需要在图像的空域信号矩阵进行补零边缘延拓（补零后的一个周期信号如下右图红色框所示）

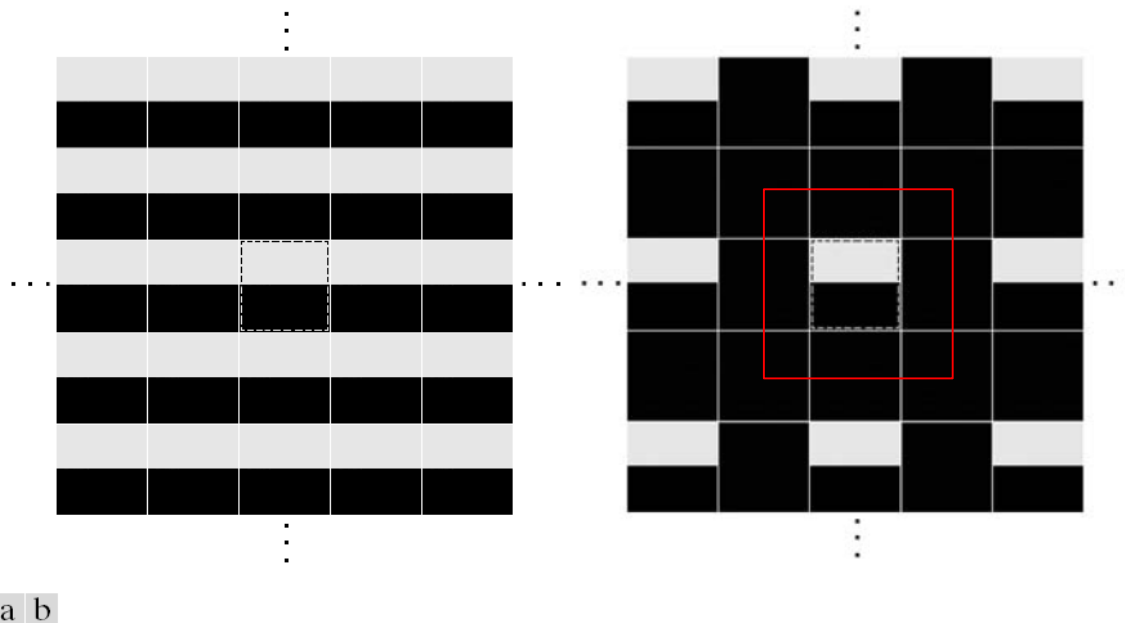
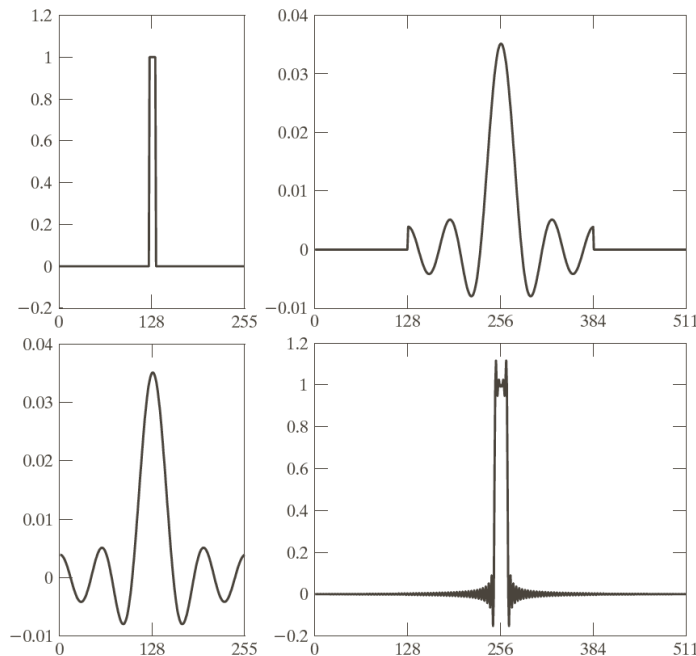

FIGURE 4.33 2-D image periodicity inherent in using the DFT. (a) Periodicity without image padding. (b) Periodicity after padding with 0s (black). The dashed areas in the center correspond to the image in Fig. 4.32(a). (The thin white lines in both images are superimposed for clarity; they are not part of the data.)

使用DFT时二维图像固有的周期性

□ 频率滤波存在的问题示例

- 理想低通滤波器的空域形式具有sinc函数形状，含无限扩展成分
- 在空域滤波时，必须对sinc函数进行截断，而截断后的sinc函数所对应的频域滤波器出现振铃成分（如下d图）
- 缓解方案：对图像的外边界用0填充，然后在频域滤波
 - ✓ 使用DFT时，图像和滤波器的大小必须相同



a c
b d

FIGURE 4.34
(a) Original filter specified in the (centered) frequency domain. (b) Spatial representation obtained by computing the IDFT of (a). (c) Result of padding (b) to twice its length (note the discontinuities). (d) Corresponding filter in the frequency domain obtained by computing the DFT of (c). Note the ringing caused by the discontinuities in (c). (The curves appear continuous because the points were joined to simplify visual analysis.)

空间和频率域滤波间的对应

空间域滤波和频率域滤波之间的对应关系

例如：高斯滤波函数

$$H(u) = Ae^{-u^2/2\sigma^2}$$

σ 为标准差：

$$h(x) = \sqrt{2\pi}\sigma Ae^{-2\pi^2\sigma^2x^2}$$

傅立叶变换及其反变换因为实数。

曲线形状如右图所示：

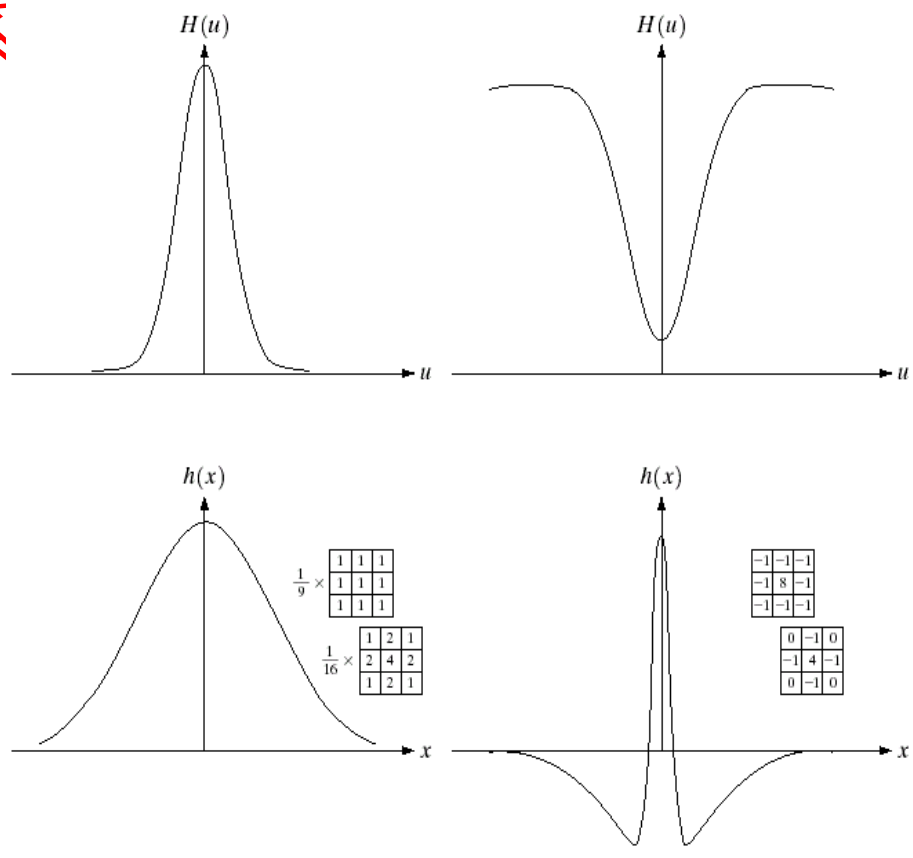

FIGURE 4.9
 (a) Gaussian frequency domain lowpass filter.
 (b) Gaussian frequency domain highpass filter.
 (c) Corresponding lowpass spatial filter.
 (d) Corresponding highpass spatial filter. The masks shown are used in Chapter 3 for lowpass and highpass filtering.



第4章 频率域滤波

- 4.1 离散傅立叶变换(DFT)
- 4.2 频率域滤波基础
- 4.3 频率域滤波器平滑图像
- 4.4 频率域滤波器锐化图像
- 4.5 选择性滤波

4.3 频率域滤波平滑

理想低通滤波器

$$H(u, v) = \begin{cases} 1 & D(u, v) \leq D_0 \\ 0 & D(u, v) > D_0 \end{cases}$$

其中， $D(u, v)$ 是频率域中点 (u, v) 与频率矩形中心的距离

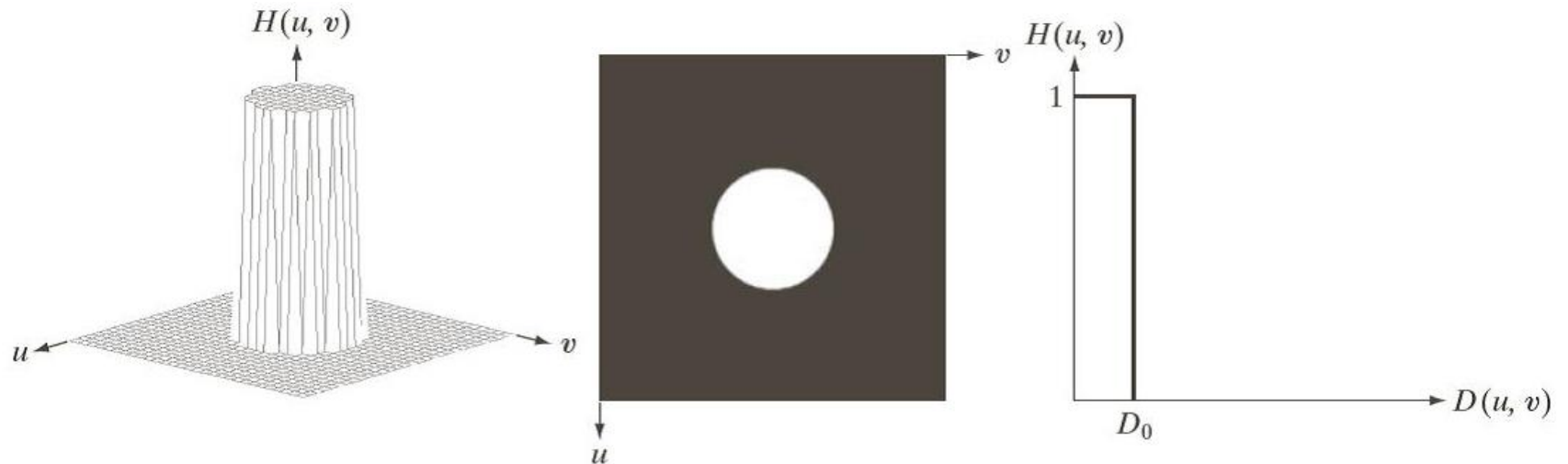

理想低通滤波器示例

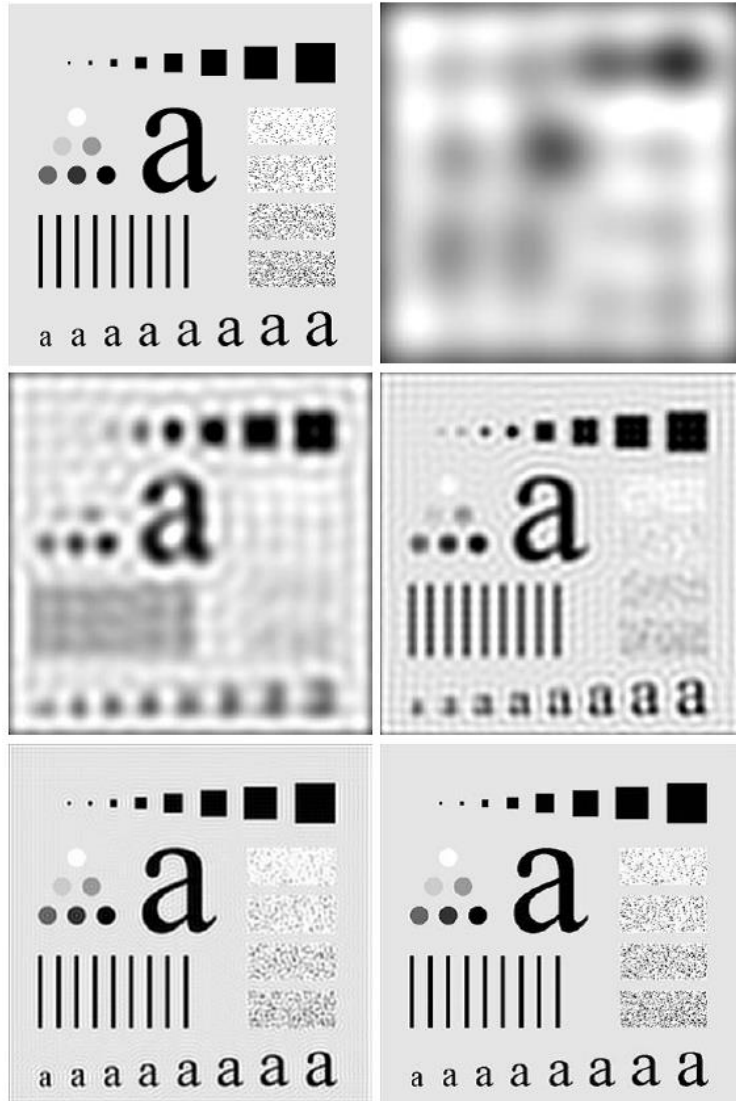

a b
c d
e f

(a) 原图
(b)-(f) 使用理想低通滤波器，截止频率设置10,30,60,160和460。这些滤波器移除的功率分别为总功率的13%，6.9%，4.3%，2.2%和0.8%。

振铃效应解释

- 理想低通滤波器ILPF所对应的空域滤波器 $h(x, y)$ 具有sinc函数形状
 - 频域的理想低通滤波 等价于 用 $h(x, y)$ 与图像直接卷积
 - sinc函数的中心波瓣对图像进行模糊
 - sinc函数外侧的较小波瓣造成振铃

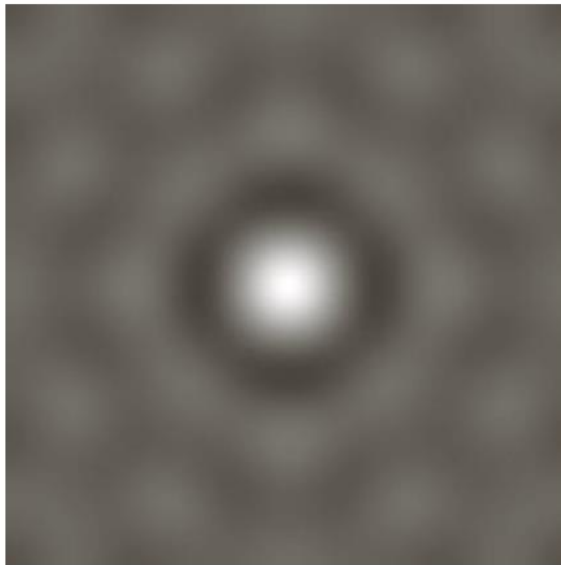

a b

FIGURE 4.43
(a) Representation in the spatial domain of an ILPF of radius 5 and size 1000×1000 .
(b) Intensity profile of a horizontal line passing through the center of the image.

4.3 频率域滤波平滑

n 阶布特沃斯低通滤波器

$$H(u, v) = \frac{1}{1 + [D(u, v) / D_0]^{2n}}$$

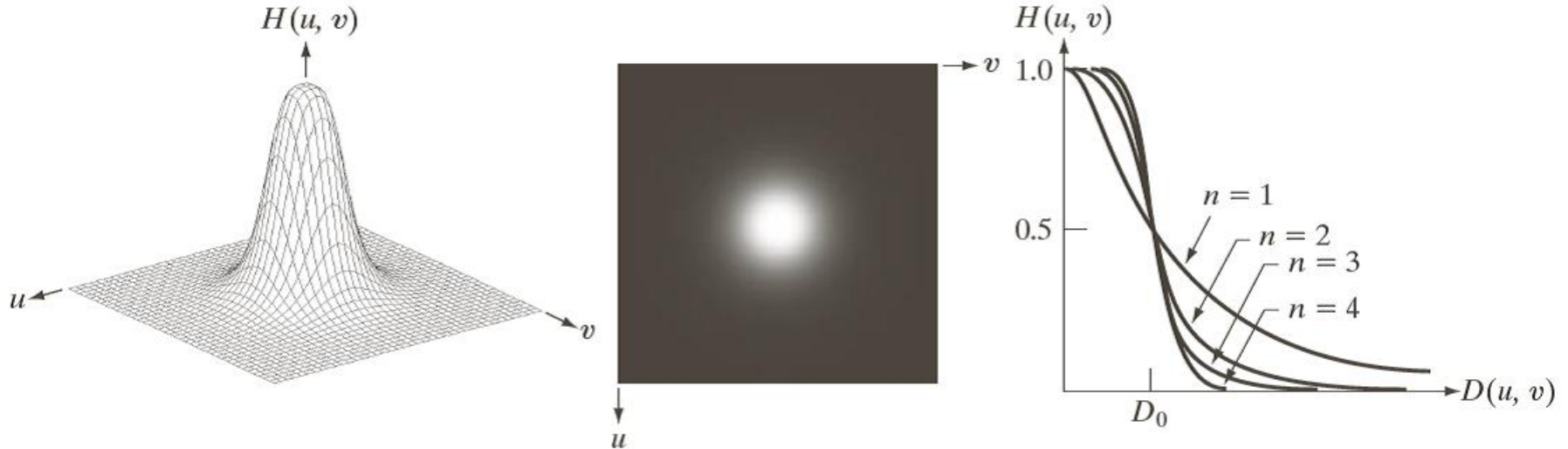

布特沃斯滤波器示例

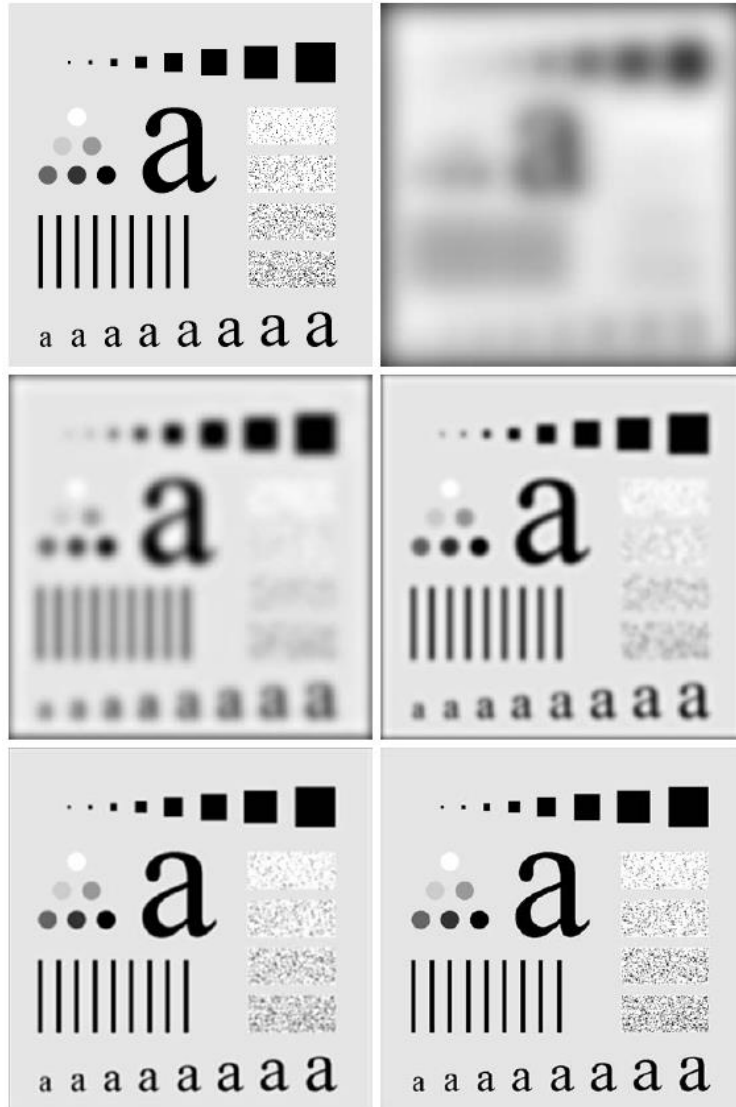

a b
c d
e f

(a) 原图
(b)-(f) 使用二阶布特沃斯低通滤波器的结果，截止频率仍为10，30，60，160和460。

4.3 频率域滤波平滑

高斯低通滤波器

$$H(u, v) = e^{-D^2(u, v) / 2D_0^2}$$

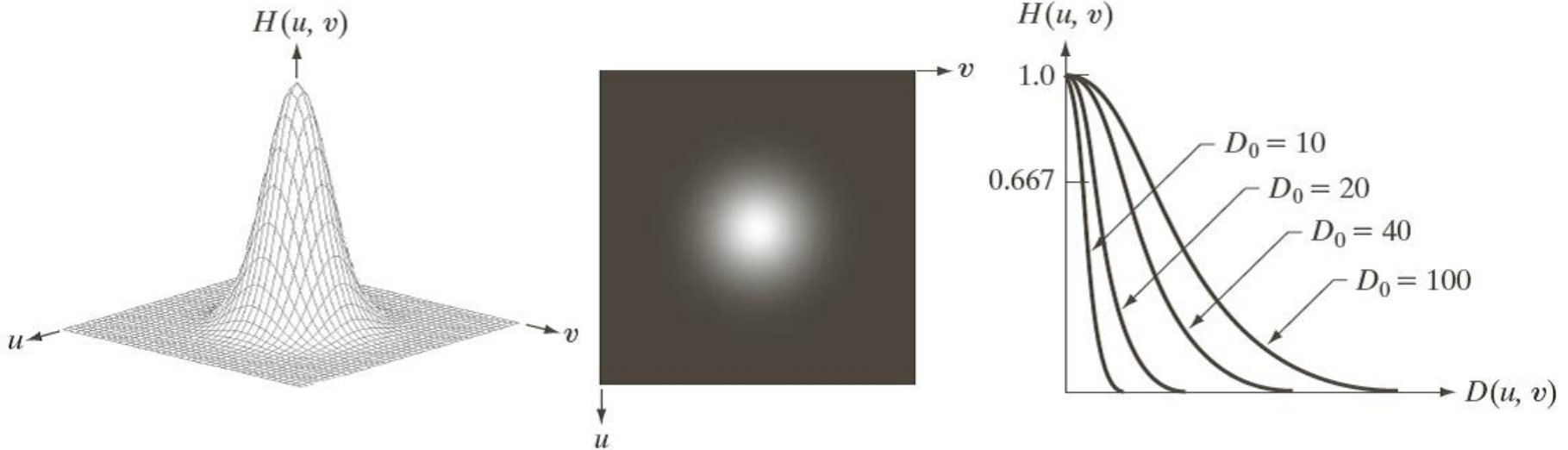

高斯低通滤波器（GLPF）的傅里叶反变换也是高斯的，因此通过上式的IDFT得到的空间高斯滤波器没有振铃。

高斯低通滤波器示例

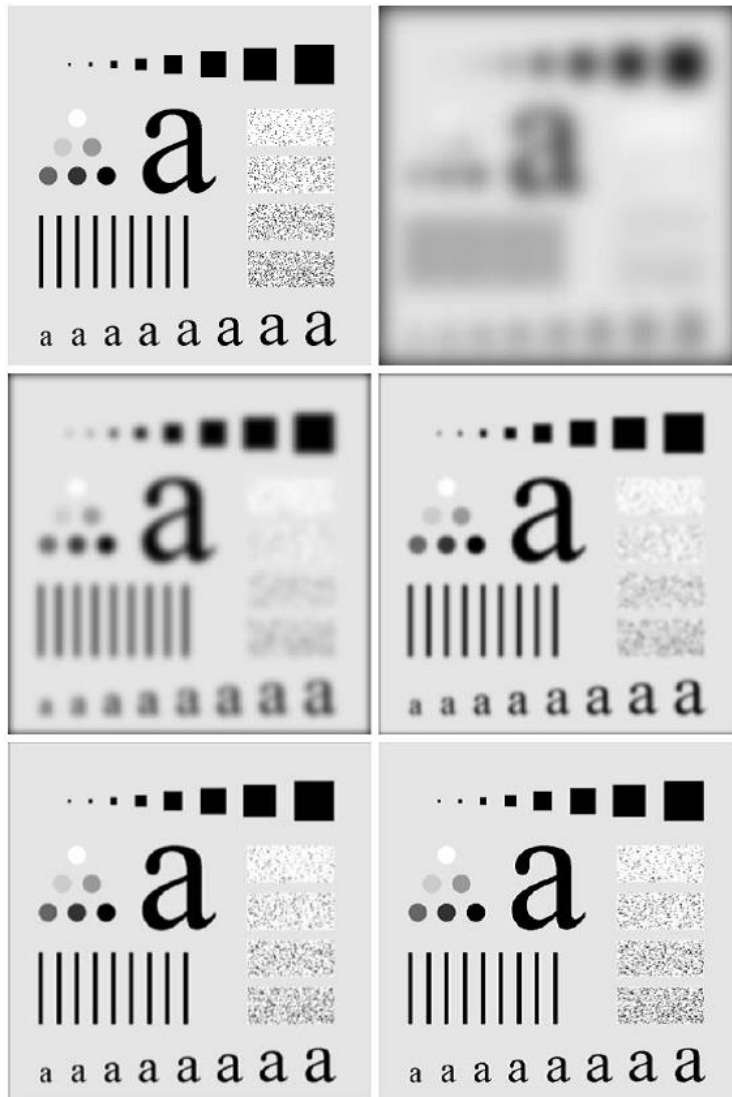

a	b
c	d
e	f

(a) 原图
(b)-(f) 使用高斯低通滤波器的结果，截止频率仍为10，30，60，160和460。

低通滤波的其他例子

1. 字符识别:

下图：断裂现象

a b

FIGURE 4.19

(a) Sample text of poor resolution (note broken characters in magnified view).
(b) Result of filtering with a GLPF (broken character segments were joined).

Historically, certain computer programs were written using only two digits rather than four to define the applicable year. Accordingly, the company's software may recognize a date using "00" as 1900 rather than the year 2000.

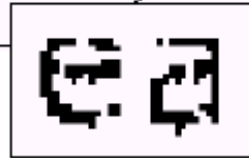

Historically, certain computer programs were written using only two digits rather than four to define the applicable year. Accordingly, the company's software may recognize a date using "00" as 1900 rather than the year 2000.



低通滤波的其他例子

2. 印刷和出版业：预处理

下图：减少面部细纹



a b c

FIGURE 4.20 (a) Original image (1028×732 pixels). (b) Result of filtering with a GLPF with $D_0 = 100$. (c) Result of filtering with a GLPF with $D_0 = 80$. Note reduction in skin fine lines in the magnified sections of (b) and (c).

低通滤波的其他例子

3. 卫星和航空图像:

下图: 墨西哥湾和佛罗里达图像存在“扫描线”
(用高斯低通来处理)



a b c

FIGURE 4.21 (a) Image showing prominent scan lines. (b) Result of using a GLPF with $D_0 = 30$. (c) Result of using a GLPF with $D_0 = 10$. (Original image courtesy of NOAA.)



第4章 频率域滤波

- 4.1 离散傅立叶变换(DFT)
- 4.2 频率域滤波基础
- 4.3 频率域滤波器平滑图像
- 4.4 频率域滤波器锐化图像
- 4.5 选择性滤波

4.4 频率域滤波锐化

理想高通滤波器

$$H(u, v) = \begin{cases} 0 & D(u, v) \leq D_0 \\ 1 & D(u, v) > D_0 \end{cases}$$

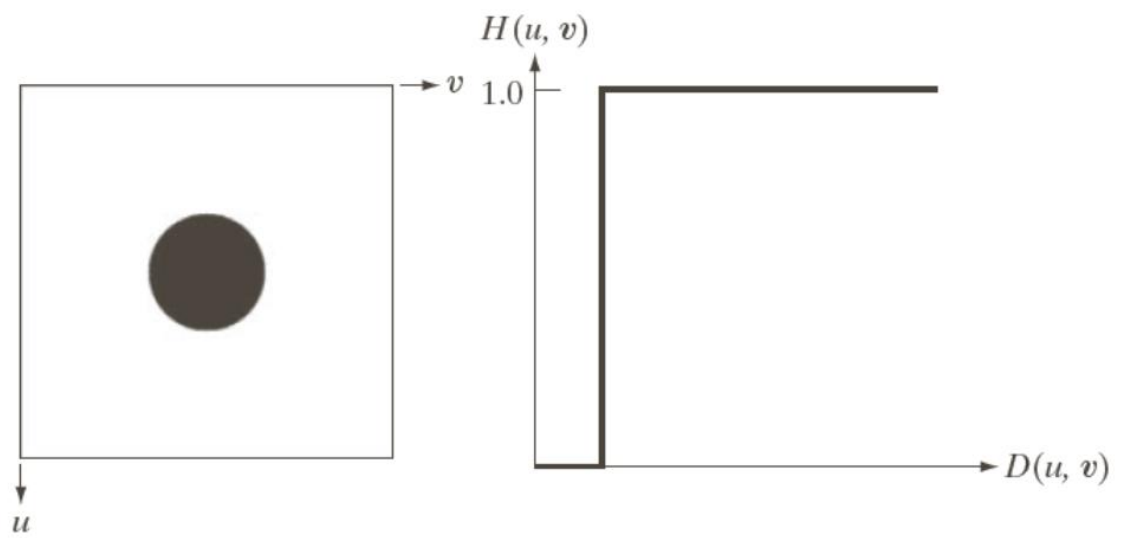
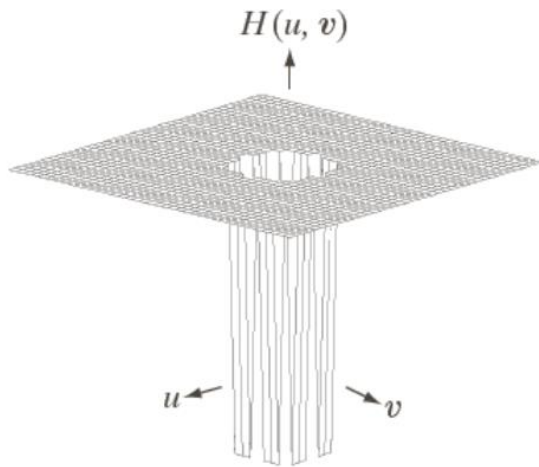

理想高通滤波器示例

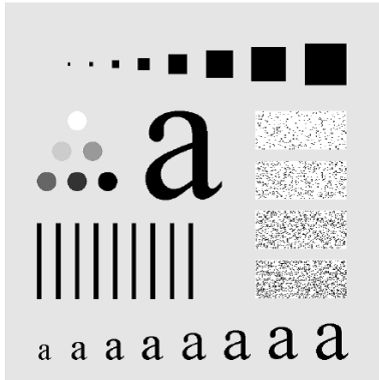

原图

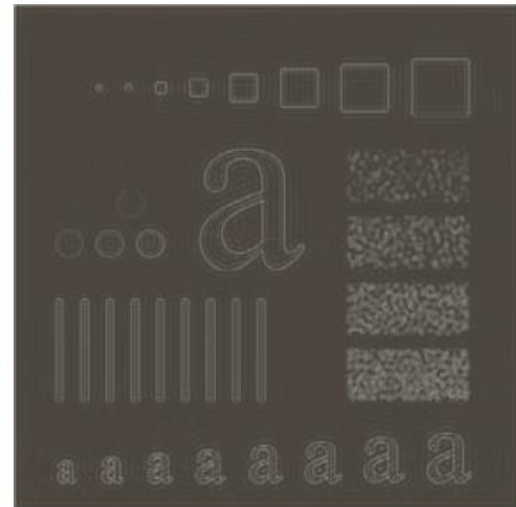
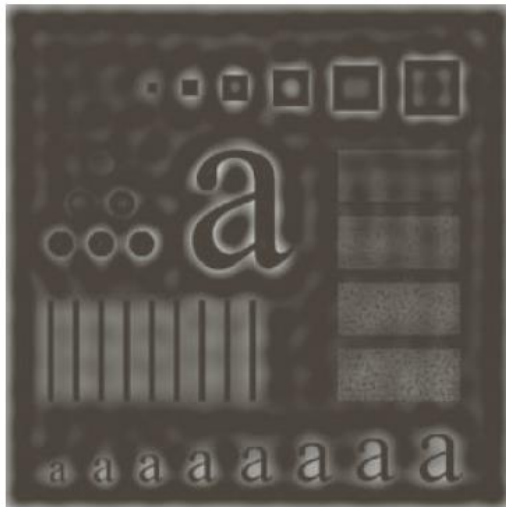

a b c

$D_0 = 30, 60, 100$ 的理想高通滤波器结果

4.4 频率域滤波锐化

布特沃斯高通滤波器

$$H(u, v) = \frac{1}{1 + [D_0 / D(u, v)]^{2n}}$$

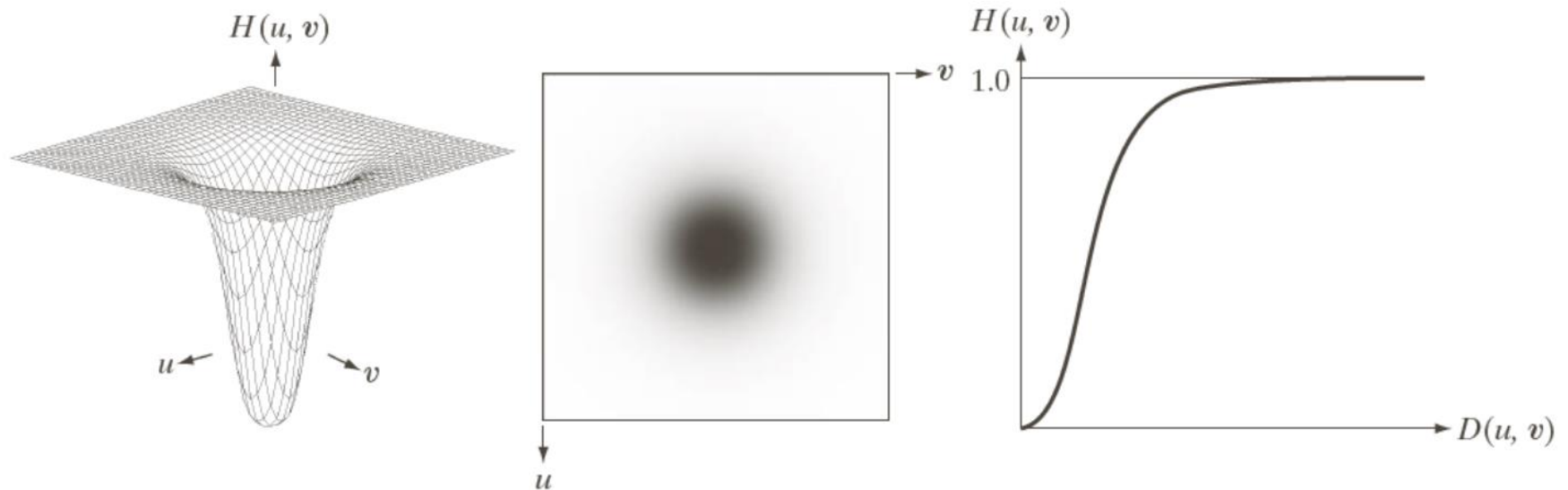

布特沃斯高通滤波器示例

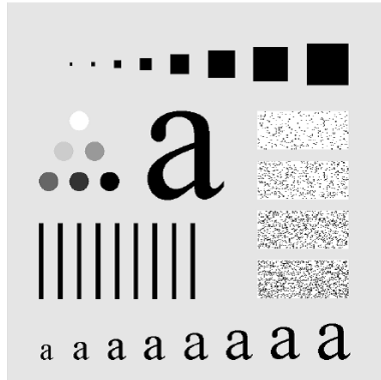

a b c

$D_0 = 30, 60, 100$ 的2阶布特沃斯高通滤波器结果

4.4 频率域滤波锐化

高斯高通滤波器

$$H(u, v) = 1 - e^{-D^2(u, v) / 2D_0^2}$$

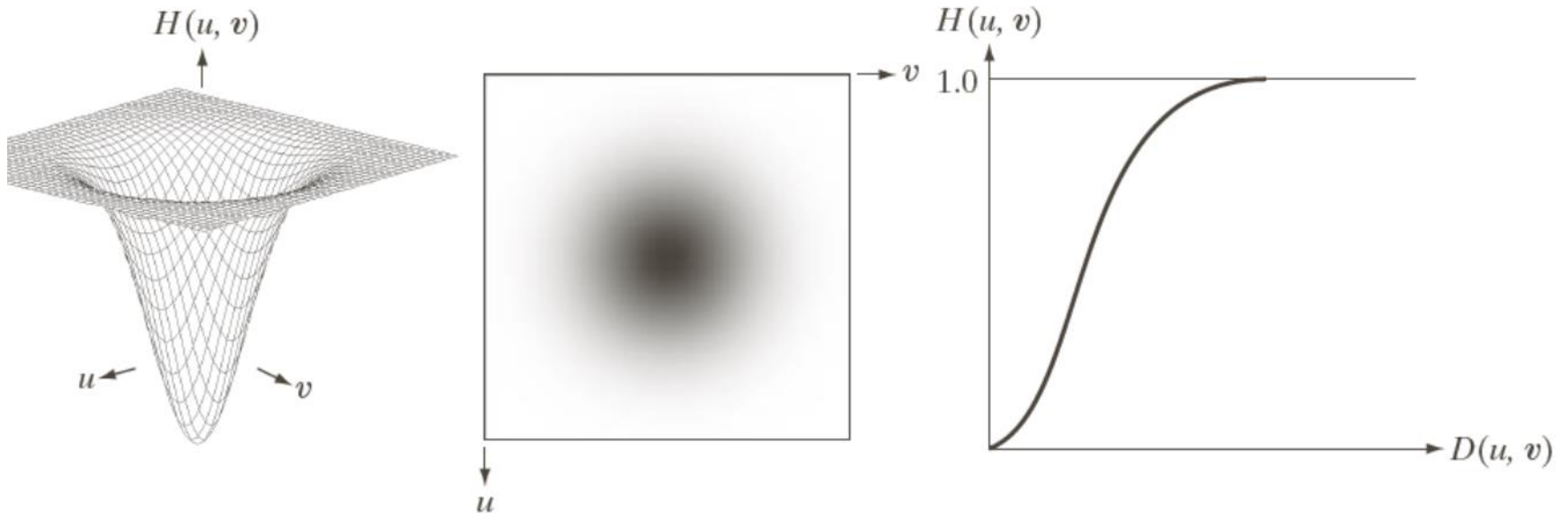

高斯高通滤波器示例

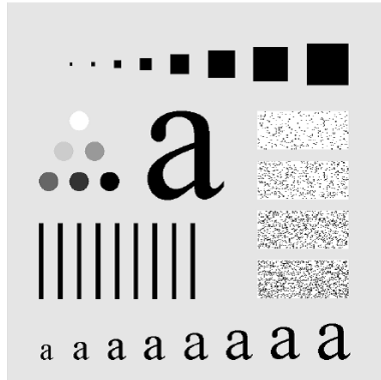

原图

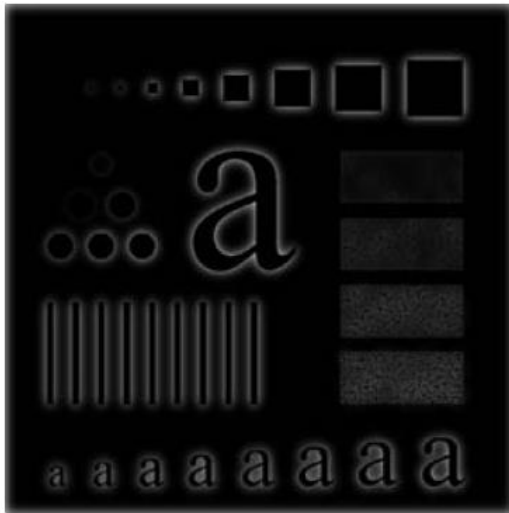

a b c

$D_0 = 30, 60, 100$ 的高斯高通滤波器结果



4.4 频率域滤波锐化：同态滤波

- 一幅图像 $f(x,y)$ 可以表示为照射分量和反射分量的乘积。

$$f(x,y) = i(x,y)r(x,y)$$

- 然而上式不能用来直接对两部分分量分别进行操作，因为两个函数乘积的傅立叶变换是不可分的。

$$F\{f(x,y)\} \neq F\{i(x,y)\}F\{r(x,y)\}$$

- 我们对图像函数两边取对数，则可以将两个分量分开。

$$z(x,y) = \ln f(x,y) = \ln i(x,y) + \ln r(x,y)$$

$$F\{\ln f(x,y)\} = F\{\ln i(x,y)\} + F\{\ln r(x,y)\}$$



同态滤波步骤

1. 两边取对数: $f(x,y) = \ln i(x,y) + \ln r(x,y)$

2. 两边取付氏变换: $F(u,v) = I(u,v) + R(u,v)$

3. 用一频域函数 $H(u,v)$ 处理 $F(u,v)$:

$$H(u,v)F(u,v) = H(u,v) I(u,v) + H(u,v) R(u,v)$$

4. 反变换到空域:

$$s(x,y) = i'(x,y) + r'(x,y)$$

5. 两边取指数:

$$g(x,y) = \exp\{i'(x,y)\} \exp\{r'(x,y)\} = i_0(x,y) r_0(x,y)$$



同态滤波步骤及滤波器径向剖面图

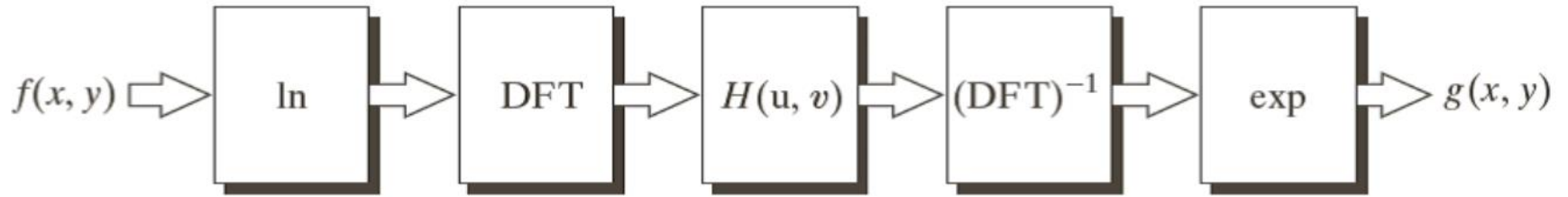

同态滤波器函数径向剖面图：滤波器函数趋向于衰减低频的贡献，而增强高频的贡献。

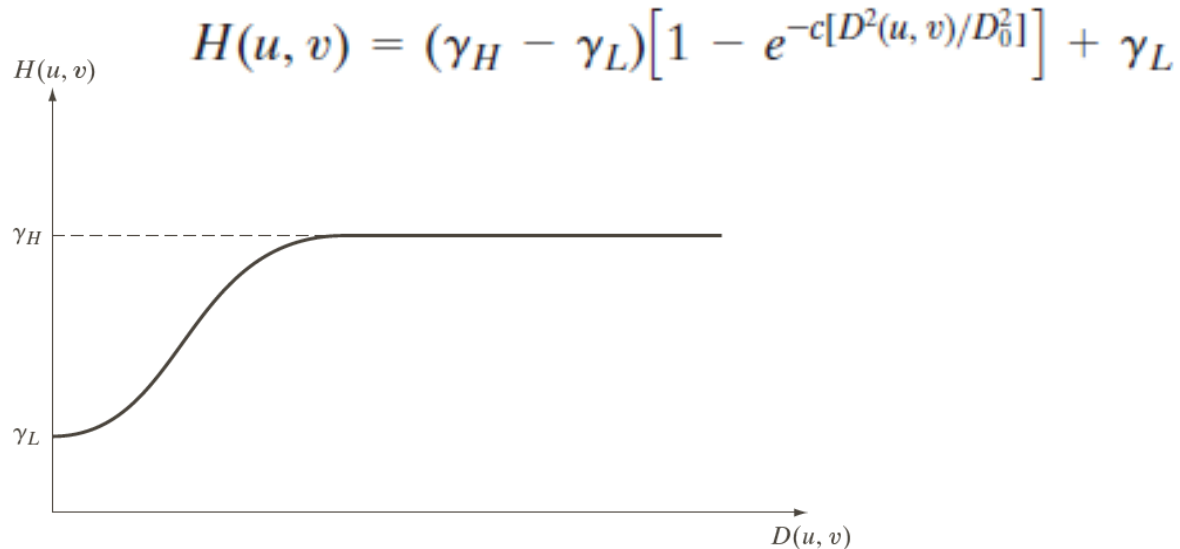

同态滤波示例

- **特点：**能消除乘性噪声，能同时压缩图象的整体动态范围和增加图象中相邻区域间的对比度
- **示例一：**

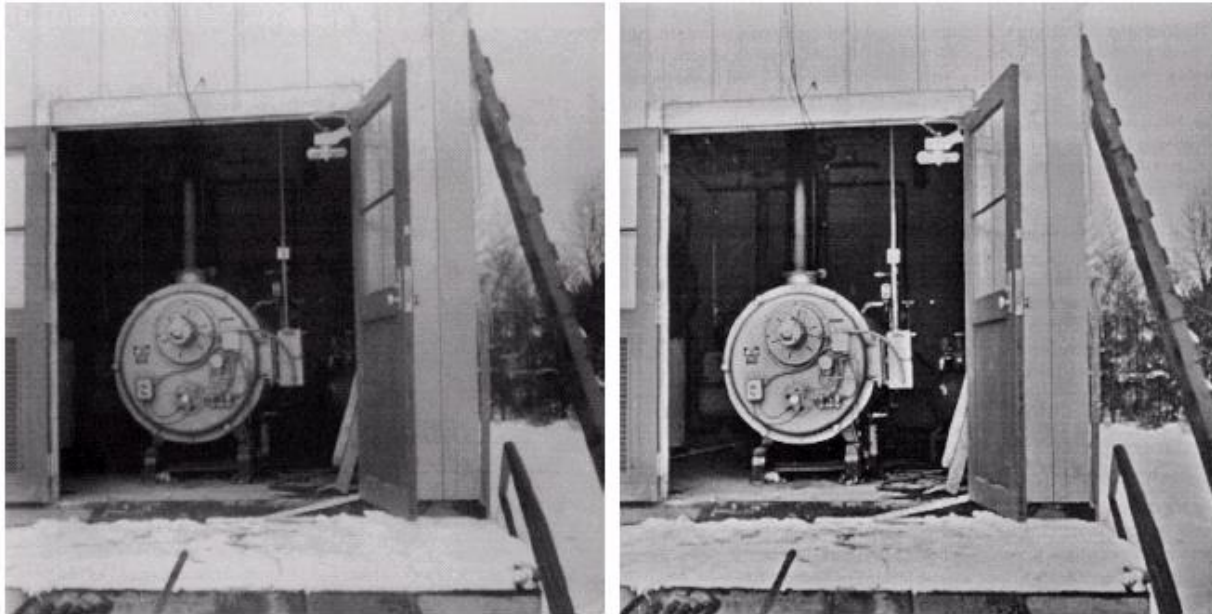

同态滤波示例

同态滤波示例二：

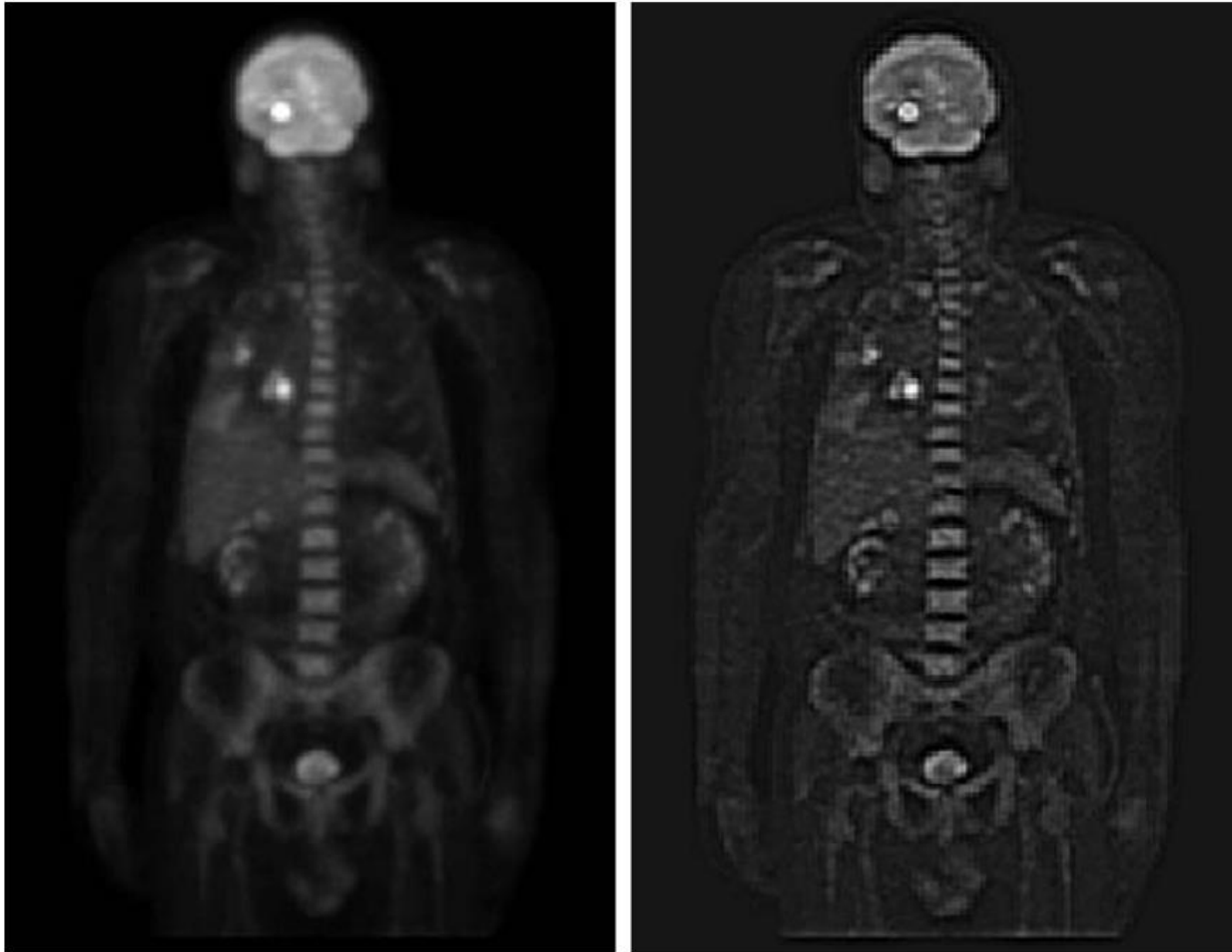



第4章 频率域滤波

- 4.1 离散傅立叶变换(DFT)
- 4.2 频率域滤波基础
- 4.3 频率域滤波器平滑图像
- 4.4 频率域滤波器锐化图像
- 4.5 选择性滤波

带阻滤波器和带通滤波器

□ 三种典型的带阻滤波器：理想、巴特沃斯、高斯

TABLE 4.6

Bandreject filters. W is the width of the band, D is the distance $D(u, v)$ from the center of the filter, D_0 is the cutoff frequency, and n is the order of the Butterworth filter. We show D instead of $D(u, v)$ to simplify the notation in the table.

Ideal	Butterworth	Gaussian
$H(u, v) = \begin{cases} 0 & \text{if } D_0 - \frac{W}{2} \leq D \leq D_0 + \frac{W}{2} \\ 1 & \text{otherwise} \end{cases}$	$H(u, v) = \frac{1}{1 + \left[\frac{DW}{D^2 - D_0^2} \right]^{2n}}$	$H(u, v) = 1 - e^{-\left[\frac{D^2 - D_0^2}{DW} \right]^2}$

□ 理想带阻、带通滤波器

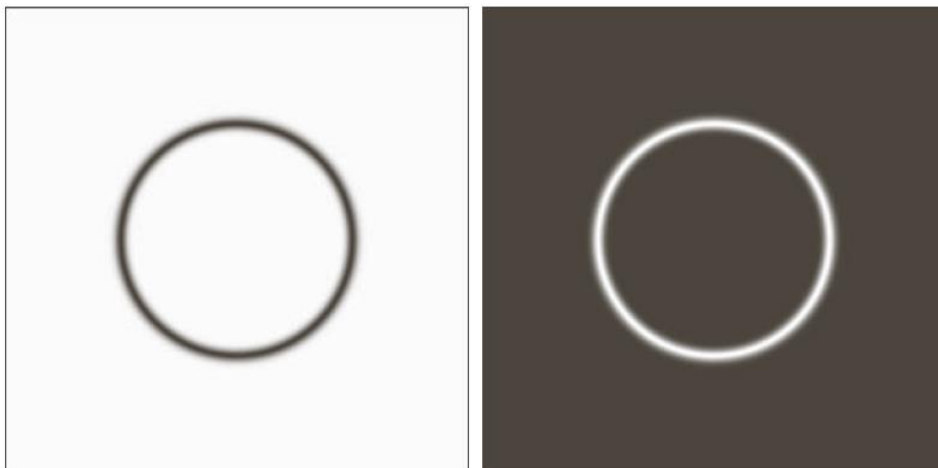

a b

FIGURE 4.63

(a) Bandreject Gaussian filter.
 (b) Corresponding bandpass filter.
 The thin black border in (a) was added for clarity; it is not part of the data.



陷波滤波器

- 陷波滤波器：拒绝（或通过）事先定义的频率矩形中心的一个邻域的频率
- 一般设计为零相移滤波器，其关于原点对称
 - 零相移：不改变原图像频域表达式中的相角的滤波器
 - 一个中心位于 (u_0, v_0) 的陷波在位置 $(-u_0, -v_0)$ 处必须有一个对应的陷波
- 一般形式：

$$H_{NR}(u, v) = \prod_{k=1}^Q H_k(u, v) \cdot H_{-k}(u, v)$$

$H_k(u, v)$ 、 $H_{-k}(u, v)$ 是高通滤波器，它们的中心分别位于 (u_k, v_k) 、 $(-u_k, -v_k)$ 处。

陷波滤波器

□ 使用陷波滤波器减少莫尔纹

- 摩尔纹是一种在摄影、扫描或者显示过程中经常出现的干涉条纹现象

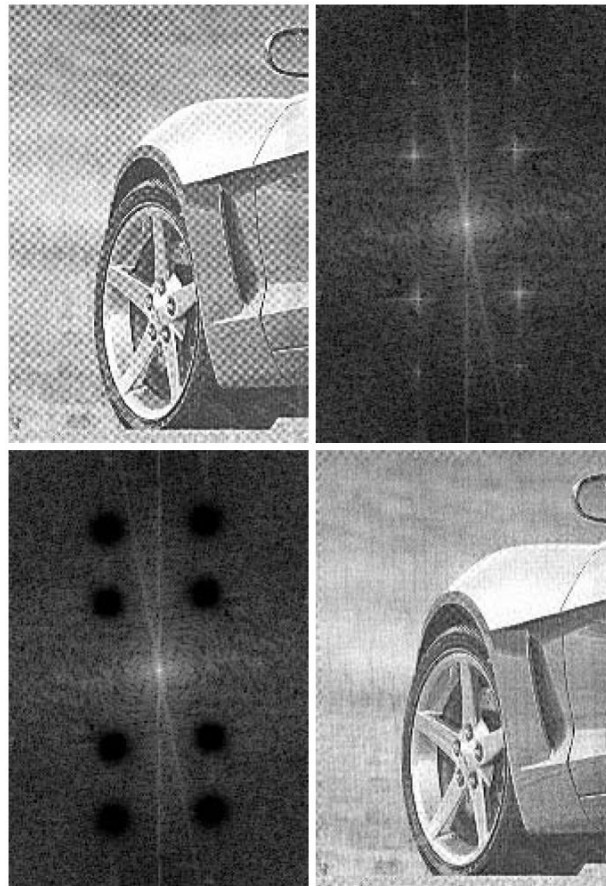

a b
c d

FIGURE 4.64

(a) Sampled newspaper image showing a moiré pattern.
(b) Spectrum.
(c) Butterworth notch reject filter multiplied by the Fourier transform.
(d) Filtered image.

陷波滤波器

□ 使用陷波滤波器增强土星图像

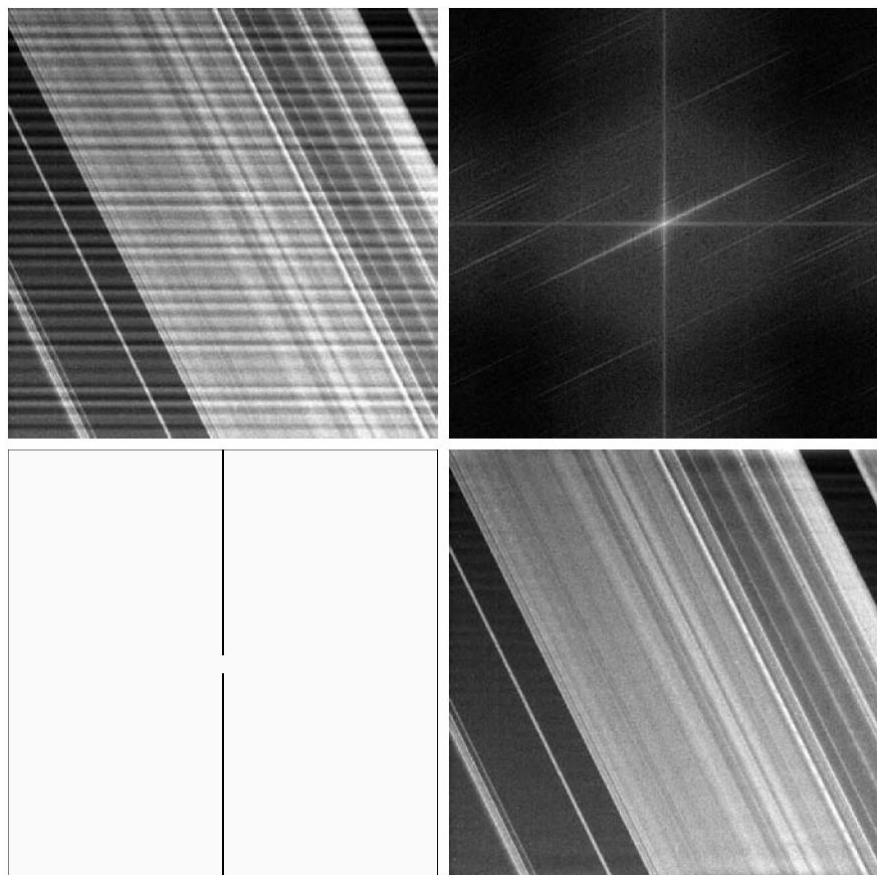

a b
c d

FIGURE 4.65
 (a) 674×674 image of the Saturn rings showing nearly periodic interference. (b) Spectrum: The bursts of energy in the vertical axis near the origin correspond to the interference pattern. (c) A vertical notch reject filter. (d) Result of filtering. The thin black border in (c) was added for clarity; it is not part of the data. (Original image courtesy of Dr. Robert A. West, NASA/JPL.)

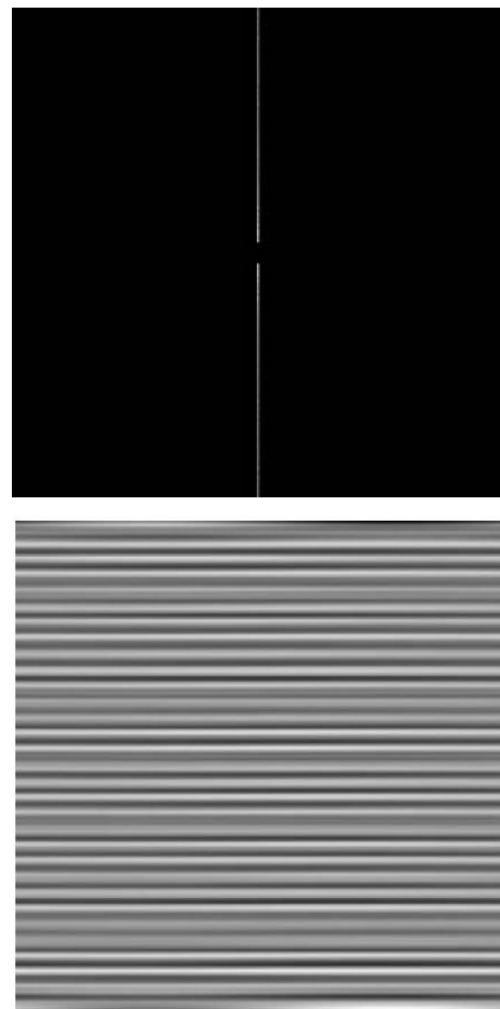

a b

FIGURE 4.66
 (a) Result (spectrum) of applying a notch pass filter to the DFT of Fig. 4.65(a). (b) Spatial pattern obtained by computing the IDFT of (a).